

AFRDI APPROVED

Brochure



RIO

TASK MESH SEATING



FEATURES

Adjustable seat height // Adjustable back height (ratchet) // Adjustable seat and back angle // Optional adjustable arms
Optional drafting kit // Available in high and low back // Moulded seat foam // Java seat // Mesh back
3 lever ergonomic mechanism // 600mm black nylon base // Available in Metro black only // AFRDI tested to level 6
Minor assembly required // Suitable for indoor use only // 7 year warranty // Weight limit is 130kg



Blue Tick Product Certification

Approved by **Furntech-AFRDI**
*Check website www.furntech.org.au for current certification status
Certificate No. **18062/4**
Nominal Expiry* **2 September 2028**

Product name: **Rio Mesh Chair Low and High Back Standard Seat**
Company: **Style Ergonomics Australia Pty Ltd**
Tested at: **Level 6 – Severe Commercial**

Tested for people up to 110 kg.

The Australasian Furnishing Research and Development Institute (AFRDI) hereby certify the above specified product under the AFRDI Blue Tick Product Certification Program using certification criteria based on **AS/NZS 4438:1997 (R2016) Height Adjustable Swivel Chairs**, and on additional requirements and variations as deemed appropriate by Furntech-AFRDI.

The company, identified above, has agreed to maintain the compliance of the product represented on this certificate, and to submit to retesting and auditing as appropriate.

NB. This product meets all of the strength, durability and stability requirements of the Standard but has some intentional variations to the requirements of the Functional Dimensions.

Testing and evaluation was conducted such that, in the opinion of Furntech-AFRDI, all products claiming AFRDI Approval that are assembled from the components designated on this certificate, should perform satisfactorily in relation to the certification criteria.

This certificate does not relate to fabrics or other upholstery coverings – chairs cannot comply with the Standard unless the fabrics or coverings used (if any) meet the flammability requirements of **AS/NZS 4088.1** and the care labelling requirements of **AS/NZS 1957**.

This certification is valid for three years but may be suspended, revoked or renewed.

Components	Identification
Arms: Height Adjustable	Style I-C Arms
Mechanism	Style MECH 26
Seat Slider	No
Pedestal Base	Style BAS1-300 Black Base Style BAS1-350 Black Base Style BAS4 Chrome Base
Minimum Class of Gas Spring	Class 1
Gas Spring	Style GAS1A
Castors: Friction	Style CAST11-OFF/SF Style CAST11-OFF/HF
Castors: Free Wheeling	Style CAST11 Black Castor
Foam: Seat	Style Moulded Foam
Mesh	Style Mesh

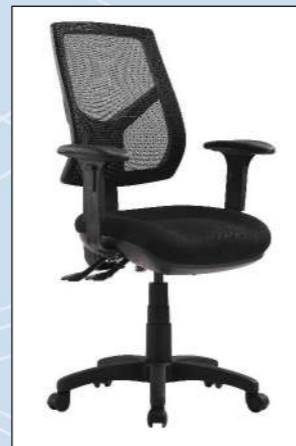

18062-4_251001_ct.docx

Australasian Furnishing Research & Development Institute Limited
ABN 44 009 579 908, trading as Furntech
School Road (University Campus) Newnham Drive PO Box 2042 Launceston Tasmania 7250 Australia
Tel (03) 6326 6155 Fax (03) 6326 3090
www.furntech.org.au Email: info@furntech.org.au



Standards, Testing and Product Certification for Commercial, Domestic and Nursery Furniture in Australia and New Zealand

INDOOR USE ONLY

X Do not use as a step ladder

OPTIONAL ADJUSTABLE ARMS

RIGHT BACK LEVER
To adjust back angle

RIGHT FRONT LEVER
To adjust seat height

To adjust back height hold back with two hands while seated and raise to desired height
To lower the back height raise back all the way to the top and release slowly

LEFT LEVER
To adjust seat angle

600MM BLACK NYLON 5 STAR BASE WITH CASTORS
Use soft tyred castors for tiles
Use hard tyred castors for carpet

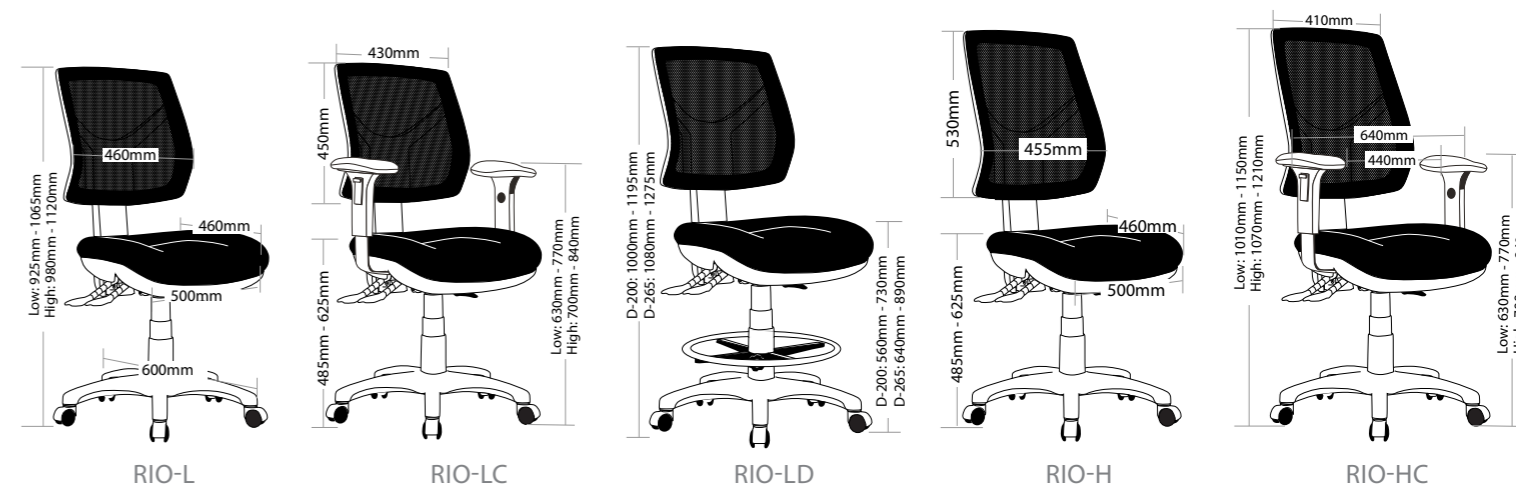

HINO

TASK MESH SEATING

FEATURES

Adjustable seat height // Adjustable back height (ratchet) // Adjustable seat and back angle // Adjustable weight tension
 Optional adjustable arms // Moulded seat foam // Mega big boy seat // Mesh back // 3 lever heavy duty ergonomic mechanism
 700mm black nylon base // Chair not available with drafting kit // Available in Metro black only // AFRDI tested to level 6
 Minor assembly required // Suitable for indoor use only // 7 year warranty // Weight limit is 140kg



HINO



HINO-C



BACK VIEW



Blue Tick
Product
Certification

Approved by Furntech-AFRDI

*Check website www.furntech.org.au for current certification status

Certificate No.
18059/5

Nominal Expiry*
2 September 2028

Product name: **HINO & HINO-C
High Back
Extra Large Seat**

Company: **Style Ergonomics Australia Pty Ltd**

Tested at: **Level 6 – Severe Commercial**

Tested for people up to 110 kg.

The Australasian Furnishing Research and Development Institute (AFRDI) hereby certify the above specified product under the AFRDI Blue Tick Product Certification Program using certification criteria based on **AS/NZS 4438:1997 (R2016) Height Adjustable Swivel Chairs**, and on additional requirements and variations as deemed appropriate by Furntech-AFRDI.

The company, identified above, has agreed to maintain the compliance of the product represented on this certificate, and to submit to retesting and auditing as appropriate.

NB. This product meets all of the strength, durability and stability requirements of the Standard but has some intentional variations to the requirements of the Functional Dimensions.

Testing and evaluation was conducted such that, in the opinion of Furntech-AFRDI, all products claiming AFRDI Approval that are assembled from the components designated on this certificate, should perform satisfactorily in relation to the certification criteria.

This certificate does not relate to fabrics or other upholstery coverings – chairs cannot comply with the Standard unless the fabrics or coverings used (if any) meet the flammability requirements of **AS/NZS 4088.1** and the care labelling requirements of **AS/NZS 1957**.

This certification is valid for three years but may be suspended, revoked or renewed.

Components	Identification
Arms: Height Adjustable	Style I-C Arms
Mechanism	Style MECH28
Seat Slider	No
Pedestal Base	Style BAS1-350 Black Base Style BAS4 Chrome Base
Minimum Class of Gas Spring	Class 2
Gas Spring	Style GAS2A
Castors: Friction	Style CAST1-OFF/SF Style CAST1-OFF/HF
Castors: Free Wheeling	Style CAST1 Black Castor
Foam: Seat	Style Moulded Foam
Foam: Back	Style Moulded Foam



18059-5_251013_ct.docx

Australasian Furnishing Research & Development Institute Limited

ABN 44 009 579 908, trading as Furntech
 School Road (University Campus) Newnham Drive PO Box 2042 Launceston Tasmania 7250 Australia
 Tel (03) 6326 6155 Fax (03) 6326 3090
www.furntech.org.au Email: info@furntech.org.au



Standards, Testing and Product Certification for Commercial, Domestic and Nursery Furniture in Australia and New Zealand

INDOOR USE ONLY

X Do not use as a step ladder

OPTIONAL
ADJUSTABLE ARMS

RIGHT BACK LEVER
To adjust back angle

RIGHT MIDDLE LEVER
To adjust seat angle

RIGHT FRONT LEVER
To adjust seat height

700MM BLACK NYLON 5 STAR
BASE WITH CASTORS

Use soft tyred castors for tiles
Use hard tyred castors for carpet

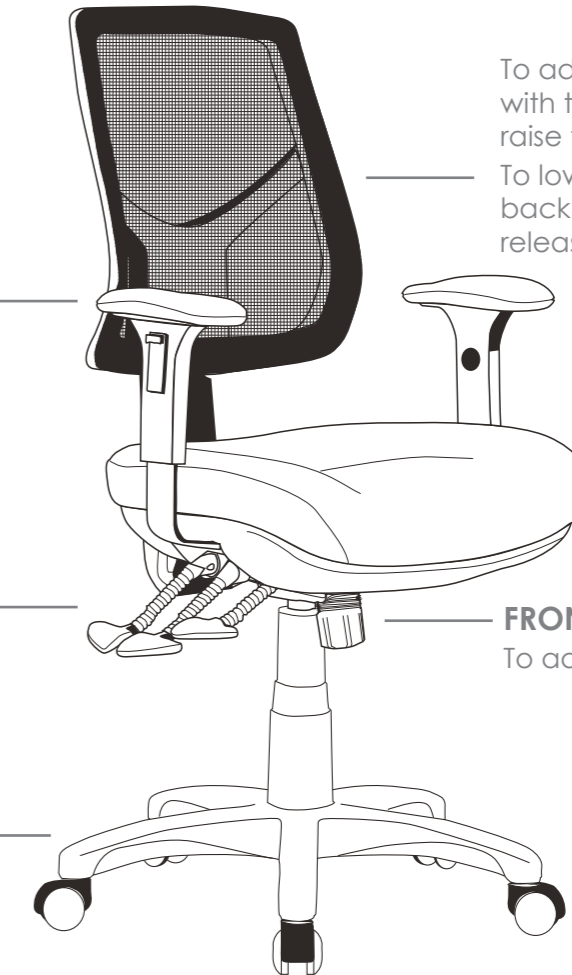

To adjust back height hold back with two hands while seated and raise to desired height
 To lower the back height raise back all the way to the top and release slowly

FRONT KNOB
To adjust weight tension

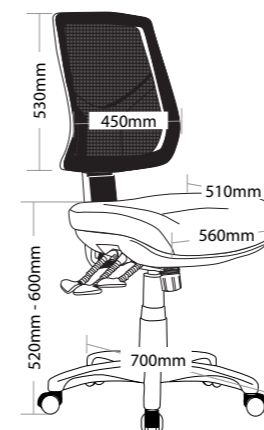

HINO

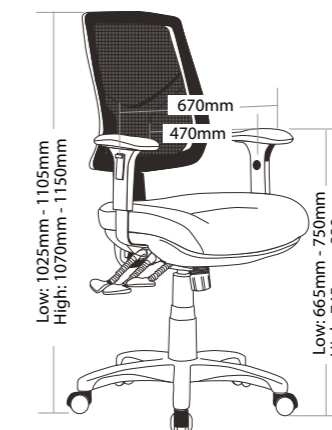

HINO-C

BRENT

TASK MESH SEATING



FEATURES

Adjustable seat height // Adjustable back height (ratchet) // Adjustable back and seat angle // Adjustable weight tension
 Adjustable seat depth (build-in seat slider) // Adjustable lumbar support // Optional adjustable arms // Moulded seat foam
 Big boy seat // Mesh back // 3 lever ergonomic heavy duty mechanism // 700mm black nylon base // Available in Metro black only
 AFRDI tested to level 6 // Suitable for indoor use only // 7 year warranty // Weight limit is 140kg



BRENT

BRENT-C

BACK VIEW



Approved by Furntech-AFRDI

*Check website www.furntech.org.au for current certification status

Certificate No.
16778/1

Nominal Expiry*
7 February 2026

Blue Tick
Product
Certification

Product name: **BRENT & BRENT-C**

Company: **Style Ergonomics Australia Pty Ltd**

Tested at: **Level 6 – Severe Commercial**

The Australasian Furnishing Research and Development Institute (AFRDI) hereby certify the above specified product under the AFRDI Blue Tick Product Certification Program using certification criteria based on **AS/NZS 4438:1997 (R2016) Height Adjustable Swivel Chairs**, and on additional requirements and variations as deemed appropriate by Furntech-AFRDI.

The company, identified above, has agreed to maintain the compliance of the product represented on this certificate, and to submit to retesting and auditing as appropriate.

NB. This product meets all of the strength, durability and stability requirements of the Standard but has some intentional variations to the requirements of the Functional Dimensions.

Testing and evaluation was conducted such that, in the opinion of Furntech-AFRDI, all products claiming AFRDI Approval that are assembled from the components designated on this certificate, should perform satisfactorily in relation to the certification criteria.

This certificate does not relate to fabrics or other upholstery coverings – chairs cannot comply with the Standard unless the fabrics or coverings used (if any) meet the flammability requirements of **AS/NZS 4088.1** and the care labelling requirements of **AS/NZS 1957**.

This certification is valid for three years but may be suspended, revoked or renewed.

Components	Identification
Arms: Height Adjustable	Style I-C Arm
Mechanism	Style MECH29
Seat Slider	Yes
Pedestal Base	Style BAS1-350 Black Base Style BAS4 Chrome Base
Minimum Class of Gas Spring	Class 3
Gas Spring	Style GAS5A
Castors: Friction	Style CAST1-OFF/SF Style CAST1-OFF/HF
Castors: Free Wheeling	Style CAST1
Foam: Seat	Style Moulded
Mesh: Back	Style Moulded



16778-1_230207_ct.doc

Australasian Furnishing Research & Development Institute Limited

ABN 44 009 579 908, trading as Furntech
 School Road (University Campus) Newnham Drive PO Box 2042 Launceston Tasmania 7250 Australia
 Tel (03) 6326 6155 Fax (03) 6326 3090
www.furntech.org.au Email: info@furntech.org.au



Standards, Testing and Product Certification for Commercial, Domestic and Nursery Furniture in Australia and New Zealand

INDOOR USE ONLY

X Do not use as a step ladder

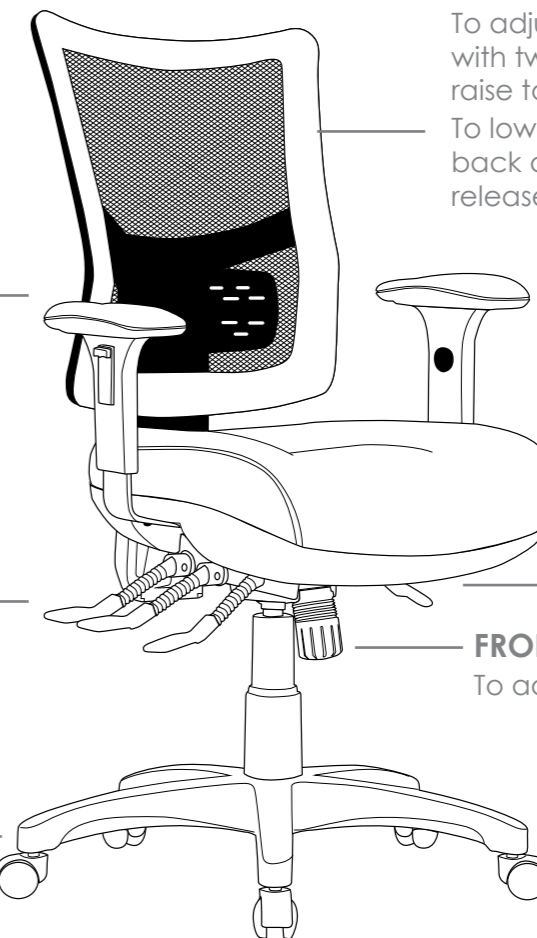

To adjust back height hold back with two hands while seated and raise to desired height
 To lower the back height raise back all the way to the top and release slowly

OPTIONAL
ADJUSTABLE ARMS

RIGHT BACK LEVER
To adjust back angle

RIGHT MIDDLE LEVER
To adjust seat angle

RIGHT FRONT LEVER
To adjust seat height

LEFT LEVER
To adjust seat depth
(Build-in seat slider)

FRONT KNOB
To adjust weight tension

700MM BLACK NYLON 5 STAR BASE WITH CASTORS

Use soft tyred castors for tiles
 Use hard tyred castors for carpet

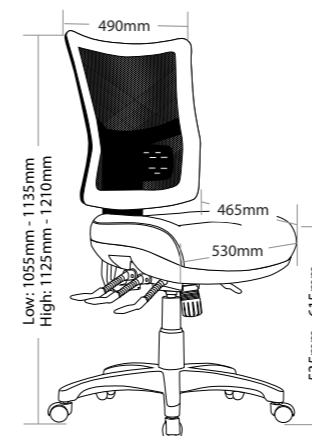

BRENT

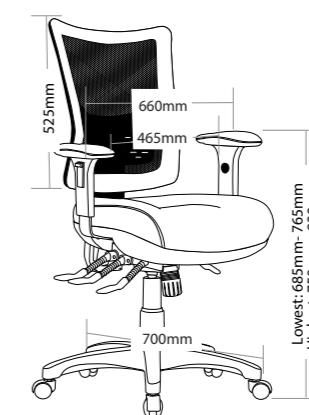

BRENT-C

FUSE

TASK MESH SEATING

FEATURES

Adjustable seat height // Adjustable back height (ratchet) // Adjustable back and seat angle // Adjustable weight tension
 Adjustable seat depth (build-in seat slider) // Adjustable lumbar support // Optional adjustable arms // Moulded seat foam
 Big boy seat // Mesh back // 3 lever ergonomic heavy duty mechanism // 700mm black nylon base // Available in Metro black only
 AFRDI tested to level 6 // Suitable for indoor use only // 7 year warranty // Weight limit is 140kg



FUSE



FUSE-C



BACK VIEW



Blue Tick
Product
Certification

Approved by Furntech-AFRDI

*Check website www.furntech.org.au for current certification status

Certificate No.
16778/2

Nominal Expiry*
7 February 2026

Product name: **FUSE & FUSE-C**

Company: **Style Ergonomics Australia Pty Ltd**

Tested at: **Level 6 – Severe Commercial**

The Australasian Furnishing Research and Development Institute (AFRDI) hereby certify the above specified product under the AFRDI Blue Tick Product Certification Program using certification criteria based on **AS/NZS 4438:1997 (R2016) Height Adjustable Swivel Chairs**, and on additional requirements and variations as deemed appropriate by Furntech-AFRDI.

The company, identified above, has agreed to maintain the compliance of the product represented on this certificate, and to submit to retesting and auditing as appropriate.

NB. This product meets all of the strength, durability and stability requirements of the Standard but has some intentional variations to the requirements of the Functional Dimensions.

Testing and evaluation was conducted such that, in the opinion of Furntech-AFRDI, all products claiming AFRDI Approval that are assembled from the components designated on this certificate, should perform satisfactorily in relation to the certification criteria.

This certificate does not relate to fabrics or other upholstery coverings – chairs cannot comply with the Standard unless the fabrics or coverings used (if any) meet the flammability requirements of **AS/NZS 4088.1** and the care labelling requirements of **AS/NZS 1957**.

This certification is valid for three years but may be suspended, revoked or renewed.

Components	Identification
Arms: Height Adjustable	Style I-C Arm
Mechanism	Style MECH29
Seat Slider	Yes
Pedestal Base	Style BAS1-350 Black Base Style BAS4 Chrome Base
Minimum Class of Gas Spring	Class 3
Gas Spring	Style GAS5A
Castors: Friction	Style CAST1-OFF/SF Style CAST1-OFF/HF
Castors: Free Wheeling	Style CAST1
Foam: Seat	Style Moulded
Mesh: Back	Fuse Mesh



16778-2_240612_ct.doc

Australasian Furnishing Research & Development Institute Limited

ABN 44 009 579 908, trading as Furntech
 School Road (University Campus) Newnham Drive PO Box 2042 Launceston Tasmania 7250 Australia
 Tel (03) 6326 6155 Fax (03) 6326 3090
www.furntech.org.au Email: info@furntech.org.au



Standards, Testing and Product Certification for Commercial, Domestic and Nursery Furniture in Australia and New Zealand

INDOOR USE ONLY

X Do not use as a step ladder

OPTIONAL
ADJUSTABLE ARMS

RIGHT BACK LEVER

To adjust back angle

RIGHT MIDDLE LEVER

To adjust seat angle

RIGHT FRONT LEVER

To adjust seat height

700MM BLACK NYLON 5 STAR
BASE WITH CASTORS

Use soft tyred castors for tiles
 Use hard tyred castors for carpet

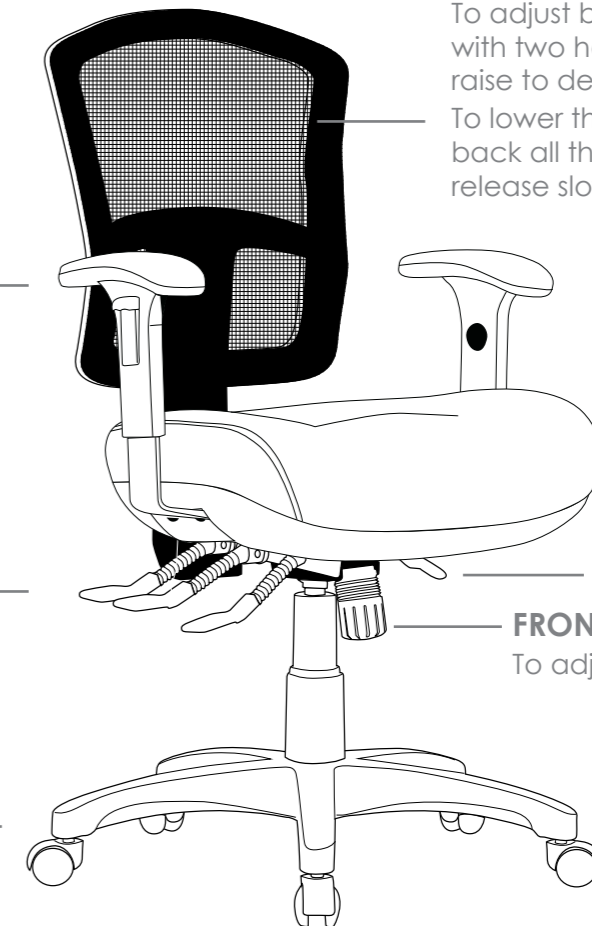

To adjust back height hold back with two hands while seated and raise to desired height

To lower the back height raise back all the way to the top and release slowly

LEFT LEVER

To adjust seat depth
(Build-in seat slider)

FRONT KNOB

To adjust weight tension

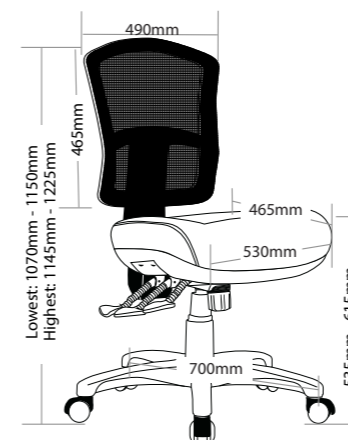

FUSE

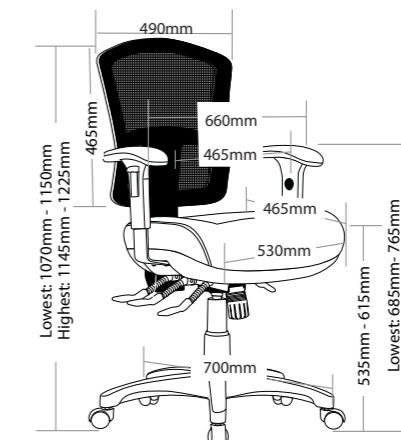

FUSE-C

P350

TASK SEATING



FEATURES

Adjustable seat height // Adjustable back height // Adjustable seat and back angle // Optional adjustable arms
 Optional drafting kit // Available in high and low back // Moulded seat and back foam // Java seat
 3 lever ergonomic mechanism // 600mm black nylon base // Available in Metro black only // AFRDI tested to level 6
 Minor assembly required // Suitable for indoor use only // 7 year warranty // Weight limit is 130kg



P350-MB P350C-MB P350D-MB P350H-MB P350HC-MB



Blue Tick
Product
Certification

Approved by Furntech-AFRDI

*Check website www.furntech.org.au for current certification status

Certificate No.
18062/1

Nominal Expiry*
2 September 2028

Product name: **Prestige P350
Low and High Back
Standard and Square Seat**

Company: **Style Ergonomics Australia Pty Ltd**

Tested at: **Level 6 – Severe Commercial**

Tested for people up to 110 kg.

The Australasian Furnishing Research and Development Institute (AFRDI) hereby certify the above specified product under the AFRDI Blue Tick Product Certification Program using certification criteria based on **AS/NZS 4438:1997 (R2016) Height Adjustable Swivel Chairs**, and on additional requirements and variations as deemed appropriate by Furntech-AFRDI.

The company, identified above, has agreed to maintain the compliance of the product represented on this certificate, and to submit to retesting and auditing as appropriate.

NB. This product meets all of the strength, durability and stability requirements of the Standard but has some intentional variations to the requirements of the Functional Dimensions.

Testing and evaluation was conducted such that, in the opinion of Furntech-AFRDI, all products claiming AFRDI Approval that are assembled from the components designated on this certificate, should perform satisfactorily in relation to the certification criteria.

This certificate does not relate to fabrics or other upholstery coverings – chairs cannot comply with the Standard unless the fabrics or coverings used (if any) meet the flammability requirements of **AS/NZS 4088.1** and the care labelling requirements of **AS/NZS 1957**.

This certification is valid for three years but may be suspended, revoked or renewed.

Components	Identification
Arms: Height Adjustable	Style I-C Arms Style Vesta Arms
Mechanism	Style MECH24 Style MECH26 Style MECH 2A
Seat Slider	No
Pedestal Base	Style BAS1-300 Black Base Style BAS1-350 Black Base Style Base-8 Spider Base Style CONBAS Chrome Spider Style BAS4 Chrome Base
Minimum Class of Gas Spring	Class 1
Gas Spring	Style GAS1A Style GAS5A
Castors: Friction	Style CAST1-OFF/SF & HF Style CAST11-OFF/SF & HF
Castors: Free Wheeling	Style CAST1 Black Castor Style CAST 11 Black Castor
Foam: Seat	Style Moulded Foam
Foam: Back	Style Moulded Foam



18062-1_251001_ct.docx

Australasian Furnishing Research & Development Institute Limited
 ABN 44 009 579 908, trading as Furntech
 School Road (University Campus) Newnham Drive PO Box 2042 Launceston Tasmania 7250 Australia
 Tel (03) 6326 6155 Fax (03) 6326 3090
www.furntech.org.au Email: info@furntech.org.au



Standards, Testing and Product Certification for Commercial, Domestic and Nursery Furniture in Australia and New Zealand

INDOOR USE ONLY

✗ Do not use as a step ladder

OPTIONAL
ADJUSTABLE ARMS

RIGHT BACK LEVER
To adjust back angle

RIGHT FRONT LEVER
To adjust seat height

600MM BLACK NYLON 5 STAR
BASE WITH CASTORS

Use soft tyred castors for tiles
Use hard tyred castors for carpet

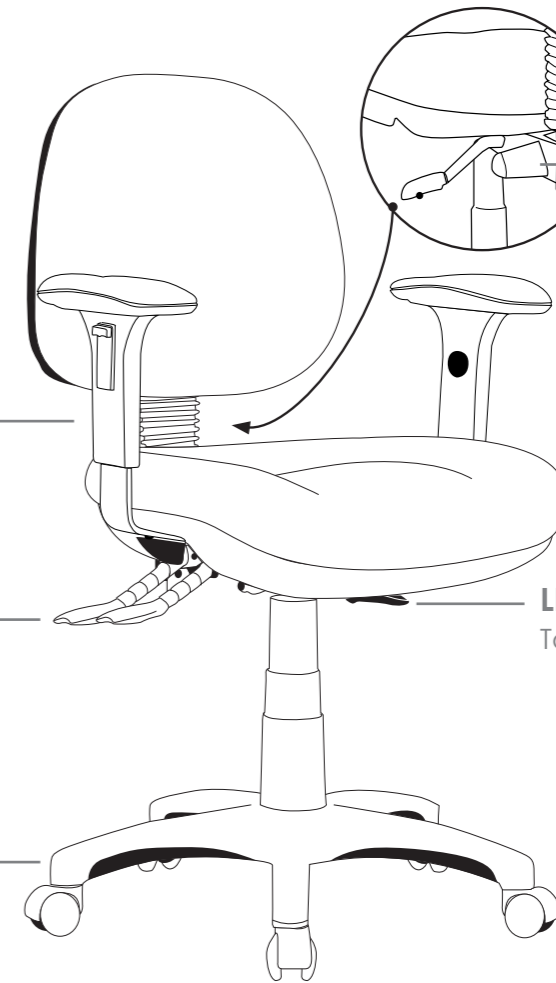

BACK KNOB
To adjust back height

LEFT LEVER
To adjust seat angle

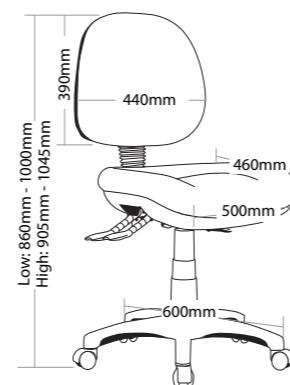

P350-MB

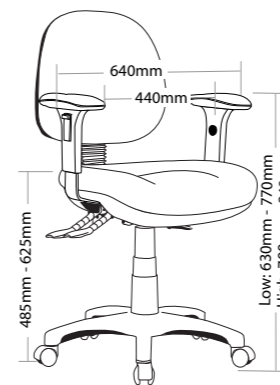

P350C-MB

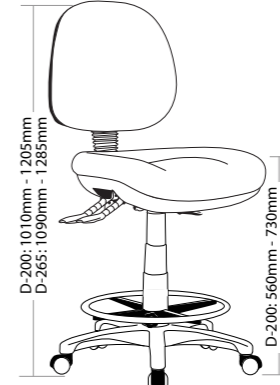

P350D-MB

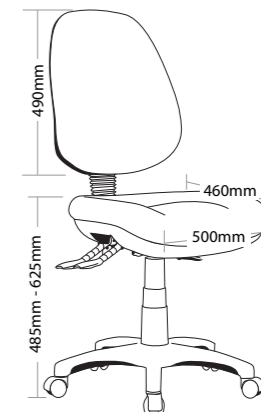

P350H-MB

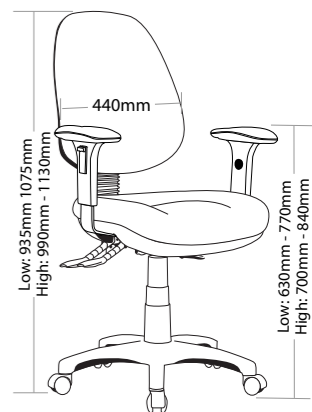

P350HC-MB

AQUA

TASK SEATING



FEATURES

Adjustable seat height // Adjustable back height (ratchet) // Adjustable seat and back angle // Optional adjustable arms
Optional drafting kit // Available in high and low back // Moulded seat and back foam // Java seat
3 lever ergonomic mechanism // 600mm black nylon base // Available in Metro black only // AFRDI tested to level 6
Minor assembly required // Suitable for indoor use only // 7 year warranty // Weight limit is 130kg



AQUA-L

AQUA-LC

AQUA-LD

AQUA-H

AQUA-HC



Blue Tick
Product
Certification

Approved by Furntech-AFRDI

*Check website www.furntech.org.au for current certification status

Certificate No.
18062/8

Nominal Expiry*
2 September 2028

Product name: **Aqua & Oriel Chair
Low and High Back
Standard Seat**

Company: **Style Ergonomics Australia Pty Ltd**

Tested at: **Level 6 – Severe Commercial**

Tested for people up to 110 kg.

The Australasian Furnishing Research and Development Institute (AFRDI) hereby certify the above specified product under the AFRDI Blue Tick Product Certification Program using certification criteria based on **AS/NZS 4438:1997 (R2016) Height Adjustable Swivel Chairs**, and on additional requirements and variations as deemed appropriate by Furntech-AFRDI.

The company, identified above, has agreed to maintain the compliance of the product represented on this certificate, and to submit to retesting and auditing as appropriate.

NB. This product meets all of the strength, durability and stability requirements of the Standard but has some intentional variations to the requirements of the Functional Dimensions.

Testing and evaluation was conducted such that, in the opinion of Furntech-AFRDI, all products claiming AFRDI Approval that are assembled from the components designated on this certificate, should perform satisfactorily in relation to the certification criteria.

This certificate does not relate to fabrics or other upholstery coverings – chairs cannot comply with the Standard unless the fabrics or coverings used (if any) meet the flammability requirements of **AS/NZS 4088.1** and the care labelling requirements of **AS/NZS 1957**.

This certification is valid for three years but may be suspended, revoked or renewed.

Components	Identification
Arms: Height Adjustable	Style HC Arms
Mechanism	Style MECH 26
Seat Slider	No
Pedestal Base	Style BAS1-300 Black Base Style BAS1-350 Black Base Style BAS4 Chrome Base
Minimum Class of Gas Spring	Class 1
Gas Spring	Style GAS1A
Castors: Friction	Style CAST11-OFF/SF Style CAST11-OFF/HF
Castors: Free Wheeling	Style CAST11 Black Castor
Foam: Seat	Style Moulded Foam
Foam: Back	Style Moulded Foam



18062-8_251001_ct.docx

Australasian Furnishing Research & Development Institute Limited

ABN 44 009 579 908, trading as Furntech

School Road (University Campus) Newnham Drive PO Box 2042 Launceston Tasmania 7250 Australia

Tel (03) 6326 6155 Fax (03) 6326 3090

www.furntech.org.au Email: info@furntech.org.au



Standards, Testing and Product Certification for Commercial, Domestic and Nursery Furniture in Australia and New Zealand

INDOOR USE ONLY

X Do not use as a step ladder

To adjust back height hold back with two hands while seated and raise to desired height

To lower the back height raise back all the way to the top and release slowly

OPTIONAL ADJUSTABLE ARMS

RIGHT BACK LEVER

To adjust back angle

RIGHT FRONT LEVER

To adjust seat height

LEFT LEVER

To adjust seat angle

600MM BLACK NYLON 5 STAR BASE WITH CASTORS

Use soft tyred castors for tiles
Use hard tyred castors for carpet

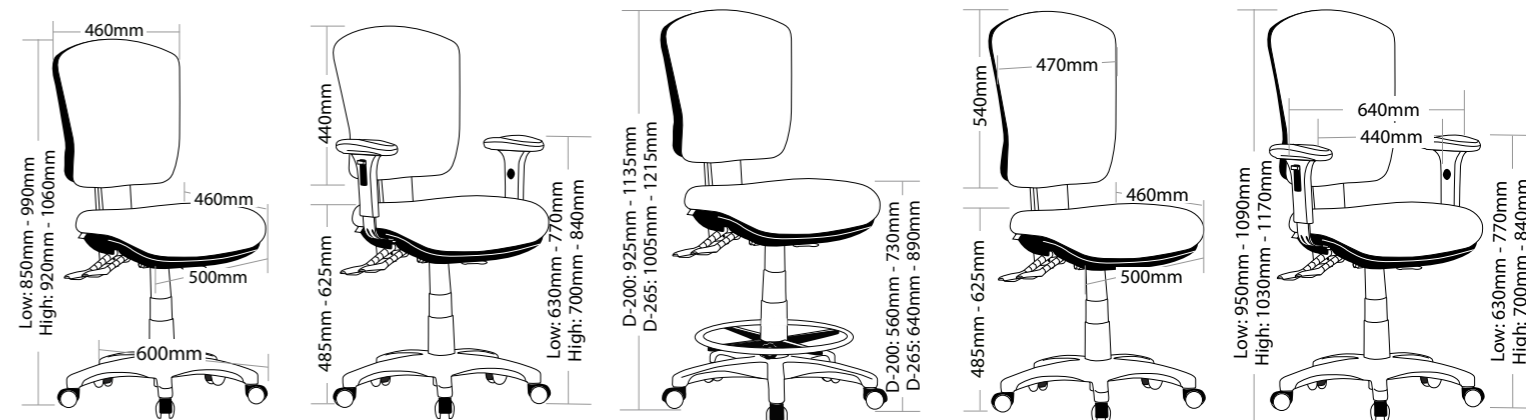

AQUA-L

AQUA-LC

AQUA-LD

AQUA-H

AQUA-HC

TR600

TASK SEATING

FEATURES

Adjustable seat height // Adjustable back height (ratchet) // Adjustable seat and back angle // Adjustable weight tension
 Optional adjustable arms // Moulded seat and back foam // Mega big boy seat // 3 lever heavy duty ergonomic mechanism
 700mm black nylon base // Chair not available with drafting kit // Available in Metro black only // AFRDI tested to level 6
 Minor assembly required // Suitable for indoor use only // 7 year warranty // Weight limit is 140kg



TR600



TR600-C



BACK VIEW



Blue Tick Product Certification

Approved by Furntech-AFRDI

*Check website www.furntech.org.au for current certification status

Certificate No. **18059/3**

Nominal Expiry* **2 September 2028**

Product name: **TR600 & TR600C High Back Extra Large Seat**

Company: **Style Ergonomics Australia Pty Ltd**

Tested at: **Level 6 – Severe Commercial**

Tested for people up to 110 kg.

The Australasian Furnishing Research and Development Institute (AFRDI) hereby certify the above specified product under the AFRDI Blue Tick Product Certification Program using certification criteria based on **AS/NZS 4438:1997 (R2016) Height Adjustable Swivel Chairs**, and on additional requirements and variations as deemed appropriate by Furntech-AFRDI.

The company, identified above, has agreed to maintain the compliance of the product represented on this certificate, and to submit to retesting and auditing as appropriate.

NB. This product meets all of the strength, durability and stability requirements of the Standard but has some intentional variations to the requirements of the Functional Dimensions.

Testing and evaluation was conducted such that, in the opinion of Furntech-AFRDI, all products claiming AFRDI Approval that are assembled from the components designated on this certificate, should perform satisfactorily in relation to the certification criteria.

This certificate does not relate to fabrics or other upholstery coverings – chairs cannot comply with the Standard unless the fabrics or coverings used (if any) meet the flammability requirements of **AS/NZS 4088.1** and the care labelling requirements of **AS/NZS 1957**.

This certification is valid for three years but may be suspended, revoked or renewed.

Components	Identification
Arms: Height Adjustable	Style I-C Arms
Mechanism	Style MECH28
Seat Slider	No
Pedestal Base	Style BAS1-350 Black Base Style BAS4 Chrome Base
Minimum Class of Gas Spring	Class 2
Gas Spring	Style GAS2A
Castors: Friction	Style CAST1-OFF/SF Style CAST1-OFF/HF
Castors: Free Wheeling	Style CAST1 Black Castor
Foam: Seat	Style Moulded Foam
Foam: Back	Style Moulded Foam



18059-3_251013_ct.docx

Australasian Furnishing Research & Development Institute Limited

ABN 44 009 579 908, trading as Furntech
 School Road (University Campus) Newnham Drive PO Box 2042 Launceston Tasmania 7250 Australia
 Tel (03) 6326 6155 Fax (03) 6326 3090
www.furntech.org.au Email: info@furntech.org.au



Standards, Testing and Product Certification for Commercial, Domestic and Nursery Furniture in Australia and New Zealand

INDOOR USE ONLY

X Do not use as a step ladder

To adjust back height hold back with two hands while seated and raise to desired height
 To lower the back height raise back all the way to the top and release slowly

OPTIONAL ADJUSTABLE ARMS

RIGHT BACK LEVER

To adjust back angle

RIGHT MIDDLE LEVER

To adjust seat angle

RIGHT FRONT LEVER

To adjust seat height

FRONT KNOB

To adjust weight tension

700MM BLACK NYLON 5 STAR BASE WITH CASTORS

Use soft tyred castors for tiles
 Use hard tyred castors for carpet

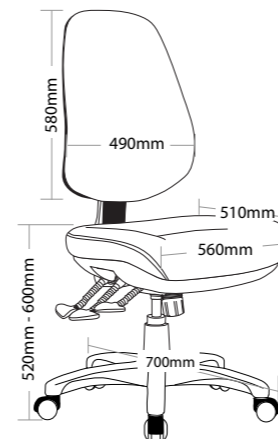

TR600

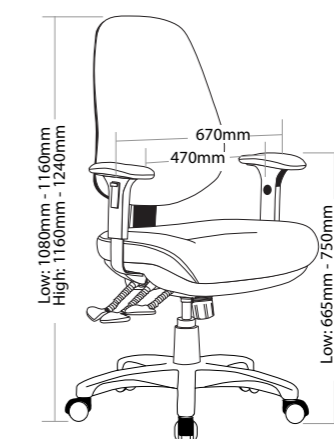

TR600-C

SPOT

TASK SEATING

FEATURES

Adjustable seat height // Adjustable back height (ratchet) // Adjustable seat and back angle // Adjustable weight tension
 Optional adjustable arms // Moulded seat and back foam // Mega big boy seat // 3 lever heavy duty ergonomic mechanism
 700mm black nylon base // Chair not available with drafting kit // Available in Metro black only // AFRDI tested to level 6
 Minor assembly required // Suitable for indoor use only // 7 year warranty // Weight limit is 140kg



SPOT



SPOT-C



BACK VIEW



Blue Tick Product Certification

Approved by Furntech-AFRDI

*Check website www.furntech.org.au for current certification status

Certificate No. **18059/6**

Nominal Expiry* **2 September 2028**

Product name: **Spot & Spot-C High Back Extra Large Seat**

Company: **Style Ergonomics Australia Pty Ltd**

Tested at: **Level 6 – Severe Commercial**

Tested for people up to 110 kg.

The Australasian Furnishing Research and Development Institute (AFRDI) hereby certify the above specified product under the AFRDI Blue Tick Product Certification Program using certification criteria based on **AS/NZS 4438:1997 (R2016) Height Adjustable Swivel Chairs**, and on additional requirements and variations as deemed appropriate by Furntech-AFRDI.

The company, identified above, has agreed to maintain the compliance of the product represented on this certificate, and to submit to retesting and auditing as appropriate.

NB. This product meets all of the strength, durability and stability requirements of the Standard but has some intentional variations to the requirements of the Functional Dimensions.

Testing and evaluation was conducted such that, in the opinion of Furntech-AFRDI, all products claiming AFRDI Approval that are assembled from the components designated on this certificate, should perform satisfactorily in relation to the certification criteria.

This certificate does not relate to fabrics or other upholstery coverings – chairs cannot comply with the Standard unless the fabrics or coverings used (if any) meet the flammability requirements of **AS/NZS 4088.1** and the care labelling requirements of **AS/NZS 1957**.

This certification is valid for three years but may be suspended, revoked or renewed.

Components	Identification
Arms: Height Adjustable	Style I-C Arms
Mechanism	Style MECH28
Seat Slider	No
Pedestal Base	Style BAS1-350 Black Base Style BAS4 Chrome Base
Minimum Class of Gas Spring	Class 2
Gas Spring	Style GAS2A
Castors: Friction	Style CAST1-OFF/SF Style CAST1-OFF/HF
Castors: Free Wheeling	Style CAST1 Black Castor
Foam: Seat	Style Moulded Foam
Foam: Back	Style Moulded Foam



18059-6_251013_ct.docx

Australasian Furnishing Research & Development Institute Limited

ABN 44 009 579 908, trading as Furntech
 School Road (University Campus) Newnham Drive PO Box 2042 Launceston Tasmania 7250 Australia
 Tel (03) 6326 6155 Fax (03) 6326 3090
www.furntech.org.au Email: info@furntech.org.au



Standards, Testing and Product Certification for Commercial, Domestic and Nursery Furniture in Australia and New Zealand

INDOOR USE ONLY

X Do not use as a step ladder

OPTIONAL ADJUSTABLE ARMS

RIGHT BACK LEVER
To adjust back angle

RIGHT MIDDLE LEVER
To adjust seat angle

RIGHT FRONT LEVER
To adjust seat height

700MM BLACK NYLON 5 STAR BASE WITH CASTORS

Use soft tyred castors for tiles
 Use hard tyred castors for carpet



To adjust back height hold back with two hands while seated and raise to desired height
 To lower the back height raise back all the way to the top and release slowly

FRONT KNOB
To adjust weight tension

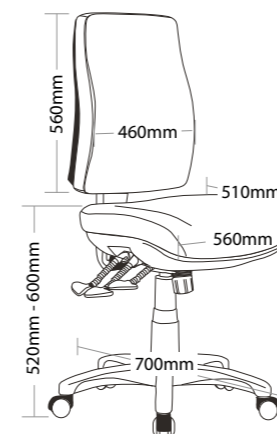

SPOT

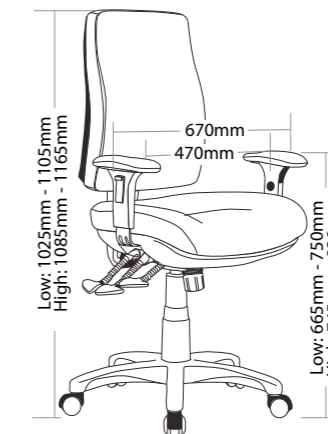

SPOT-C

NEWTON

TASK SEATING



FEATURES

Adjustable seat height // Adjustable back height (ratchet) // Adjustable seat and back angle // Adjustable weight tension
Optional adjustable arms // Moulded seat and back foam // Mega big boy seat // 3 lever heavy duty ergonomic mechanism
700mm black nylon base // Chair not available with drafting kit // Available in Metro black only // AFRDI tested to level 6
Minor assembly required // Suitable for indoor use only // 7 year warranty // Weight limit is 140kg



NEWTON



NEWTON-C



BACK VIEW



Blue Tick Product Certification

Approved by Furntech-AFRDI

*Check website www.furntech.org.au for current certification status

Certificate No. **18059/7**

Nominal Expiry* **2 September 2028**

Product name: **Newton NE600 & NE600C, Newton-MB High Back Extra Large Seat**

Company: **Style Ergonomics Australia Pty Ltd**

Tested at: **Level 6 – Severe Commercial**

Tested for people up to 110 kg.

The Australasian Furnishing Research and Development Institute (AFRDI) hereby certify the above specified product under the AFRDI Blue Tick Product Certification Program using certification criteria based on **AS/NZS 4438:1997 (R2016) Height Adjustable Swivel Chairs**, and on additional requirements and variations as deemed appropriate by Furntech-AFRDI.

The company, identified above, has agreed to maintain the compliance of the product represented on this certificate, and to submit to retesting and auditing as appropriate.

NB. This product meets all of the strength, durability and stability requirements of the Standard but has some intentional variations to the requirements of the Functional Dimensions.

Testing and evaluation was conducted such that, in the opinion of Furntech-AFRDI, all products claiming AFRDI Approval that are assembled from the components designated on this certificate, should perform satisfactorily in relation to the certification criteria.

This certificate does not relate to fabrics or other upholstery coverings – chairs cannot comply with the Standard unless the fabrics or coverings used (if any) meet the flammability requirements of **AS/NZS 4088.1** and the care labelling requirements of **AS/NZS 1957**.

This certification is valid for three years but may be suspended, revoked or renewed.

Components	Identification
Arms: Height Adjustable	Style I-C Arms
Mechanism	Style MECH28
Seat Slider	No
Pedestal Base	Style BAS1-350 Black Base Style BAS4 Chrome Base
Minimum Class of Gas Spring	Class 2
Gas Spring	Style GAS2A
Castors: Friction	Style CAST1-OFF/SF Style CAST1-OFF/HF
Castors: Free Wheeling	Style CAST1 Black Castor
Foam: Seat	Style Moulded Foam
Foam: Back	Style Moulded Foam



18059-7_251013_ct.docx

Australasian Furnishing Research & Development Institute Limited

ABN 44 009 579 908, trading as Furntech
School Road (University Campus) Newnham Drive PO Box 2042 Launceston Tasmania 7250 Australia
Tel (03) 6326 6155 Fax (03) 6326 3090
www.furntech.org.au Email: info@furntech.org.au



Standards, Testing and Product Certification for Commercial, Domestic and Nursery Furniture in Australia and New Zealand

INDOOR USE ONLY

X Do not use as a step ladder

OPTIONAL
ADJUSTABLE ARMS

RIGHT BACK LEVER
To adjust back angle

RIGHT MIDDLE LEVER
To adjust seat angle

RIGHT FRONT LEVER
To adjust seat height

700MM BLACK NYLON 5 STAR
BASE WITH CASTORS

Use soft tyred castors for tiles
Use hard tyred castors for carpet

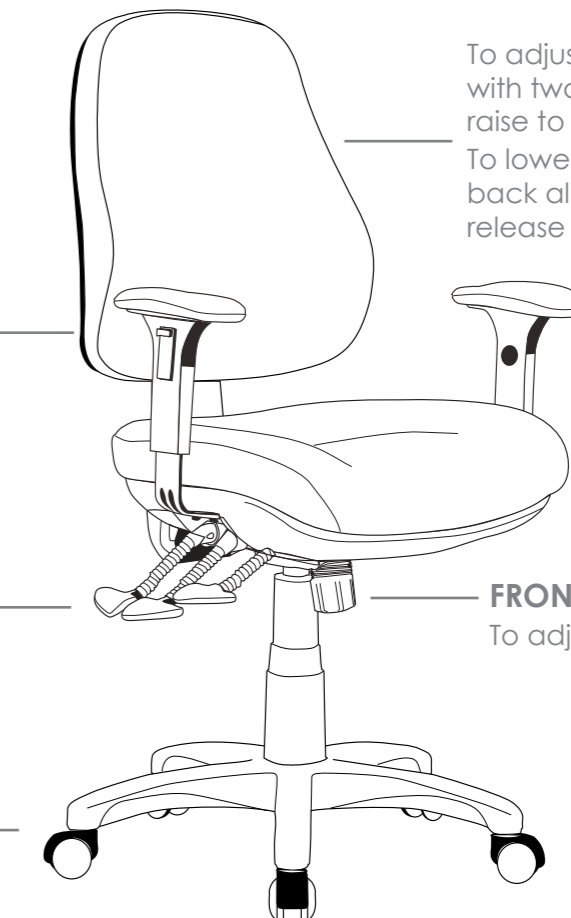

To adjust back height hold back with two hands while seated and raise to desired height
To lower the back height raise back all the way to the top and release slowly

FRONT KNOB
To adjust weight tension

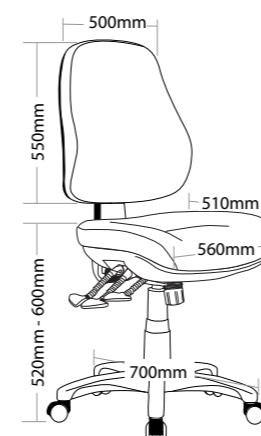

NEWTON

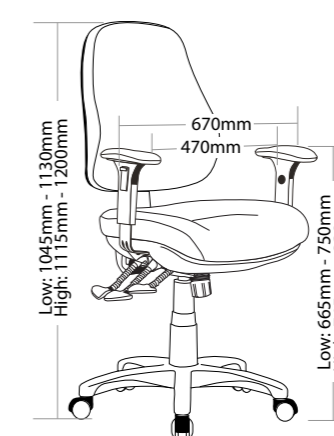

NEWTON-C

RANGER

MULTI SHIFT SEATING



FEATURES

Adjustable seat height // Adjustable seat and back angle // Adjustable seat depth (seat slider) // Forward seat tilt adjustable
 Adjustable weight tension // Adjustable headrest // Adjustable arms // Moulded seat and back foam // Saddle seat
 Synchron mechanism with 3 locking positions // Brake castor // 720mm aluminium bases // Available in black and grey only
 AFRDI tested to level 6 // AFRDI tested to multi shift use 160kg // Minor assembly required // Suitable for indoor use only
 7 year warranty // Brake castor Weight limit is 160kg



RANGER



BACK VIEW



SIDE VIEW



RATED LOAD

Blue Tick
Product
Certification

Approved by Furntech-AFRDI

*Check website www.furntech.org.au for current certification status

Certificate No.
17283/1

Nominal Expiry*
13 February 2027

Product name: **Ranger Chair**

Company: **Style Ergonomics Australia Pty Ltd**

Load rating: For people up to **160 kg**

Multiple shift operation

Static load tested to 490 kg

The Australasian Furnishing Research and Development Institute (AFRDI) hereby certify the above specified product under the AFRDI Blue Tick Product Certification Program using certification criteria based on the following Standards and on additional requirements and variations as deemed appropriate by Furntech-AFRDI. For full test results and details of the specific components allowed on this chair, see Test Report 17283/1.

AFRDI 142 - Rated Loads for Office Swivel Chairs

AS/NZS 4438:1997 (R2016) Height Adjustable Swivel Chairs at Level 6 – Severe Commercial

The company, identified above, has agreed to maintain the compliance of the product represented on this certificate, and to submit to retesting and auditing as appropriate.

This certificate does not relate to the ignitability or durability of the chair's upholstery covering (e.g. fabric or leather). The chair's seat foam and back foam have been tested to the ignitability requirements of AS/NZS 4088.1 and found to be compliant.

This certification is valid for three years but may be suspended, revoked or renewed.



17283-1_240408_ct.doc

Australasian Furnishing Research & Development Institute Limited

ABN 44 009 579 908, trading as Furntech
 School Road (University Campus) Newnham Drive PO Box 2042 Launceston Tasmania 7250 Australia
 Tel (03) 6326 6155 Fax (03) 6326 3090
www.furntech.org.au Email: info@furntech.org.au



Standards, Testing and Product Certification for Commercial, Domestic and Nursery Furniture in Australia and New Zealand

INDOOR USE ONLY

✗ Do not use as a step ladder

INNER BACK LEVER

To adjust seat angle
(Forwards)

INNER RIGHT LEVER

To adjust seat height

RIGHT KNOB

To adjust weight tension

720MM ALUMINIUM 5 STAR BASE WITH BRAKE CASTORS

Use soft tyred castors for tiles
Use hard tyred castors for carpet

ADJUSTABLE HEADREST

ADJUSTABLE ARMS

LEFT KNOB

To adjust seat and back angle

INNER LEFT LEVER

To adjust seat depth
(seat slider)

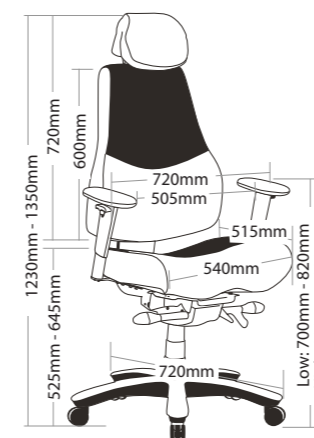

RANGER

* Please note that the Headrest should not be used to manoeuvre the chair.

IMPACT

MULTI SHIFT SEATING



FEATURES

Adjustable seat height // Adjustable seat and back angle // Adjustable seat depth (seat slider) // Forward seat tilt adjustable
 Adjustable weight tension // Adjustable lumbar support // Optional headrest // Adjustable arms // Moulded seat and back foam
 Saddle seat // Synchron mechanism with 3 locking positions // 720mm aluminium base // Brake castors
 AFRDI tested to level 6 Multi shift use 200kg // Available in black only // Minor assembly required // Suitable for indoor use only
 7 year warranty // Weight limit is 200kg



IMPACT-H



IMPACT-L



BACK VIEW



Approved by Furntech-AFRDI

*Check website www.furntech.org.au for current certification status

Certificate No.
17283/2
Nominal Expiry*
13 February 2027



Product name: **IMPACT-L & IMPACT-H**

Company: **Style Ergonomics Australia Pty Ltd**

Load rating: For people up to **160 kg**
Multiple shift operation
Static load tested to 490 kg

The Australasian Furnishing Research and Development Institute (AFRDI) hereby certify the above specified product under the AFRDI Blue Tick Product Certification Program using certification criteria based on the following Standards and on additional requirements and variations as deemed appropriate by Furntech-AFRDI. For full test results and details of the specific components allowed on this chair, see Test Reports 17283/1 and 17283/2.

AFRDI 142 - Rated Loads for Office Swivel Chairs

AS/NZS 4438:1997 (R2016) Height Adjustable Swivel Chairs at Level 6 – Severe Commercial

The company, identified above, has agreed to maintain the compliance of the product represented on this certificate, and to submit to retesting and auditing as appropriate.

This certificate does not relate to the ignitability or durability of the chair's upholstery covering (e.g. fabric or leather). The chair's seat foam and back foam have been tested to the ignitability requirements of AS/NZS 4088.1 and found to be compliant.

This certification is valid for three years but may be suspended, revoked or renewed.



17283-2_240408_ct.doc

Australasian Furnishing Research & Development Institute Limited
 ABN 44 009 570 908, trading as Furntech
 School Road (University Campus) Newnham Drive PO Box 2042 Launceston Tasmania 7250 Australia
 Tel (03) 6326 6155 Fax (03) 6326 3090
www.furntech.org.au Email: info@furntech.org.au



Standards, Testing and Product Certification for Commercial, Domestic and Nursery Furniture in Australia and New Zealand

INDOOR USE ONLY

✗ Do not use as a step ladder

INNER BACK LEVER
To adjust seat angle (Forwards)

INNER RIGHT LEVER
To adjust seat height

BACK KNOB
To adjust lumbar

RIGHT KNOB
To adjust weight tension

720MM ALUMINIUM 5 STAR BASE WITH BRAKE CASTORS
Use soft tyred castors for tiles
Use hard tyred castors for carpet

ADJUSTABLE ARMS

LEFT KNOB
To adjust seat and back angle
INNER LEFT LEVER
To adjust seat depth (seat slider)

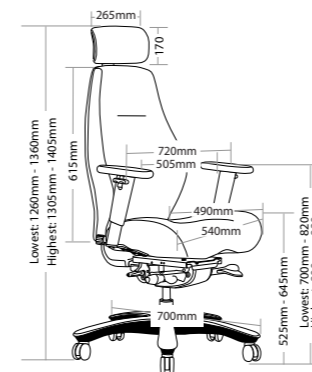

IMPACT-H

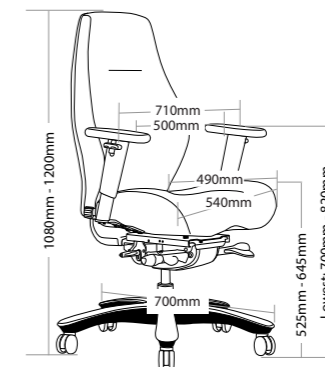

IMPACT-L

* Please note that the Headrest should not be used to manoeuvre the chair.

RAPTOR

MULTI SHIFT SEATING



FEATURES

- Adjustable seat height // Adjustable seat and back angle // Adjustable seat depth (seat slider) // Adjustable weight tension
- Adjustable lumbar support // Optional adjustable headrest // Adjustable arms // Moulded seat and back foam // Saddle seat
- Synchron mechanism with 3 locking positions // 720mm aluminium base // Brake castors // AFRDI tested to level 6
- Multi shift use 200kg // Available in black leather only // Minor assembly required
- Suitable for indoor use only // 7 year warranty // Weight limit is 200kg



RAPTOR-H



RAPTOR-L



BACK VIEW



Approved by Furntech-AFRDI

*Check website www.furntech.org.au for current certification status

Certificate No.
17283/3

Nominal Expiry*
13 February 2027



Product name: **RAPTOR**

Company: **Style Ergonomics Australia Pty Ltd**

Load rating: For people up to **160 kg**
Multiple shift operation

Static load tested to 490 kg

The Australasian Furnishing Research and Development Institute (AFRDI) hereby certify the above specified product under the AFRDI Blue Tick Product Certification Program using certification criteria based on the following Standards and on additional requirements and variations as deemed appropriate by Furntech-AFRDI. For full test results and details of the specific components allowed on this chair, see Test Reports 17283/1 and 17283/2.

AFRDI 142 - Rated Loads for Office Swivel Chairs

AS/NZS 4438:1997 (R2016) Height Adjustable Swivel Chairs at Level 6 – Severe Commercial

The company, identified above, has agreed to maintain the compliance of the product represented on this certificate, and to submit to retesting and auditing as appropriate,

This certificate does not relate to the ignitability or durability of the chair's upholstery covering (e.g. fabric or leather). The chair's seat foam and back foam have been tested to the ignitability requirements of AS/NZS 4088.1 and found to be compliant.

This certification is valid for three years but may be suspended, revoked or renewed.



17283-3_240408_ct.doc

Australasian Furnishing Research & Development Institute Limited
 ABN 44 009 570 908, trading as Furntech
 School Road (University Campus) Newnham Drive PO Box 2042 Launceston Tasmania 7250 Australia
 Tel (03) 6326 6155 Fax (03) 6326 3090
www.furntech.org.au Email: info@furntech.org.au



Standards, Testing and Product Certification for Commercial, Domestic and Nursery Furniture in Australia and New Zealand

INDOOR USE ONLY

OPTIONAL
ADJUSTABLE
HEADREST

X Do not use as a step ladder

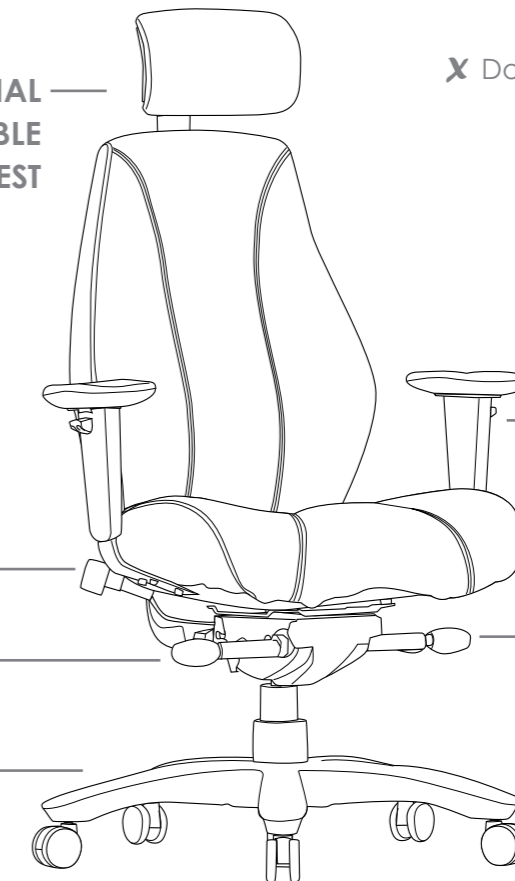

ADJUSTABLE ARMS

LEFT KNOB

To adjust seat and back angle

INNER LEFT LEVER
To adjust seat depth (seat slider)

BACK KNOB

To adjust lumbar

INNER RIGHT LEVER

To adjust seat height

RIGHT KNOB

To adjust weight tension

**720MM ALUMINIUM
5 STAR BASE WITH BRAKE CASTORS**

Use soft tyred castors for tiles
Use hard tyred castors for carpet

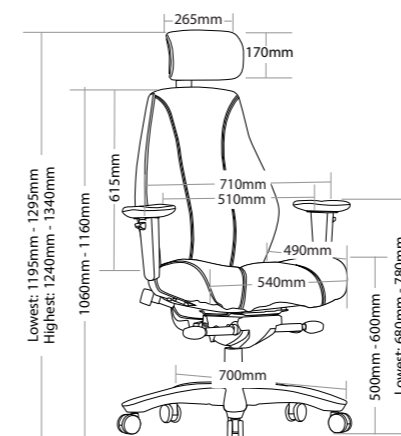

RAPTOR-H

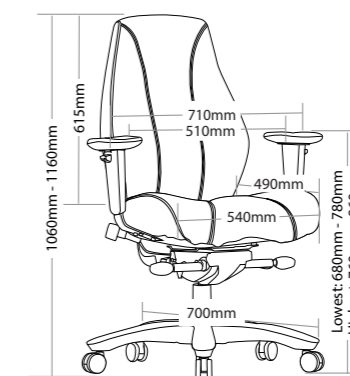

RAPTOR-L

* Please note that the Headrest should not be used to manoeuvre the chair.

AVOCA

TASK MESH SEATING



FEATURES

Adjustable seat height || Adjustable back height (ratchet) || Adjustable seat angle (with 3 lever mechanism only)
 Adjustable back angle || Optional adjustable arms || Optional seat depth (seat slider)(not available on drafting chair)
 Optional drafting kit || Optional 2 or 3 lever mechanism || Available in high and low back || Moulded seat foam
 Mesh back || Java seat || 600mm black nylon base || Available in local fabrics || Back mesh available in Jazz mesh
 AFRDI tested to level 6 || Suitable for indoor use only || 7 year warranty || Weight limit is 130kg



MAV350

MAV350C

MAV350H

MAV350HC

MAV350D



Blue Tick
Product
Certification

Approved by Furntech-AFRDI

*Check website www.furntech.org.au for current certification status

Certificate No.
18062/6

Nominal Expiry*
2 September 2028

Product name: **Avoca Mesh MAV350**
Low and High Back
Standard Seat

Company: **Style Ergonomics Australia Pty Ltd**

Tested at: **Level 6 – Severe Commercial**

Tested for people up to 110 kg.

The Australasian Furnishing Research and Development Institute (AFRDI) hereby certify the above specified product under the AFRDI Blue Tick Product Certification Program using certification criteria based on **AS/NZS 4438:1997 (R2016) Height Adjustable Swivel Chairs**, and on additional requirements and variations as deemed appropriate by Furntech-AFRDI.

The company, identified above, has agreed to maintain the compliance of the product represented on this certificate, and to submit to retesting and auditing as appropriate.

NB. This product meets all of the strength, durability and stability requirements of the Standard but has some intentional variations to the requirements of the Functional Dimensions.

Testing and evaluation was conducted such that, in the opinion of Furntech-AFRDI, all products claiming AFRDI Approval that are assembled from the components designated on this certificate, should perform satisfactorily in relation to the certification criteria.

This certificate does not relate to fabrics or other upholstery coverings – chairs cannot comply with the Standard unless the fabrics or coverings used (if any) meet the flammability requirements of **AS/NZS 4088.1** and the care labelling requirements of **AS/NZS 1957**.

This certification is valid for three years but may be suspended, revoked or renewed.

Components

Arms: Height Adjustable
Mechanism
Seat Slider
Pedestal Base

Minimum Class of Gas Spring
Gas Spring
Castors: Friction

Castors: Free Wheeling
Foam: Seat
Mesh: Back

Identification

Style I-C Arms
Style MECH 26
No
Style BAS1-300 Black Base
Style BAS1-350 Black Base
Style BAS4 Chrome Base

Class 1
Style GAS1A
Style CAST11-OFF/SF
Style CAST11-OFF/HF
Style CAST11 Black Castor
Style Moulded Foam
Style Mesh



18062-6_251001_ct.docx

Australasian Furnishing Research & Development Institute Limited

ABN 44 009 579 908, trading as Furntech

School Road (University Campus) Newnham Drive PO Box 2042 Launceston Tasmania 7250 Australia

Tel (03) 6326 6155 Fax (03) 6326 3090

www.furntech.org.au Email: info@furntech.org.au



Standards, Testing and Product Certification for Commercial, Domestic and Nursery Furniture in Australia and New Zealand

INDOOR USE ONLY

X Do not use as a step ladder

To adjust back height hold back with two hands while seated and raise to desired height
To lower the back height raise back all the way to the top and release slowly

OPTIONAL
ADJUSTABLE ARMS

RIGHT BACK LEVER
To adjust back angle

RIGHT FRONT LEVER
To adjust seat height

LEFT LEVER
To adjust seat angle

600MM BLACK NYLON 5 STAR
BASE WITH CASTORS

Use soft tyred castors for tiles
Use hard tyred castors for carpet

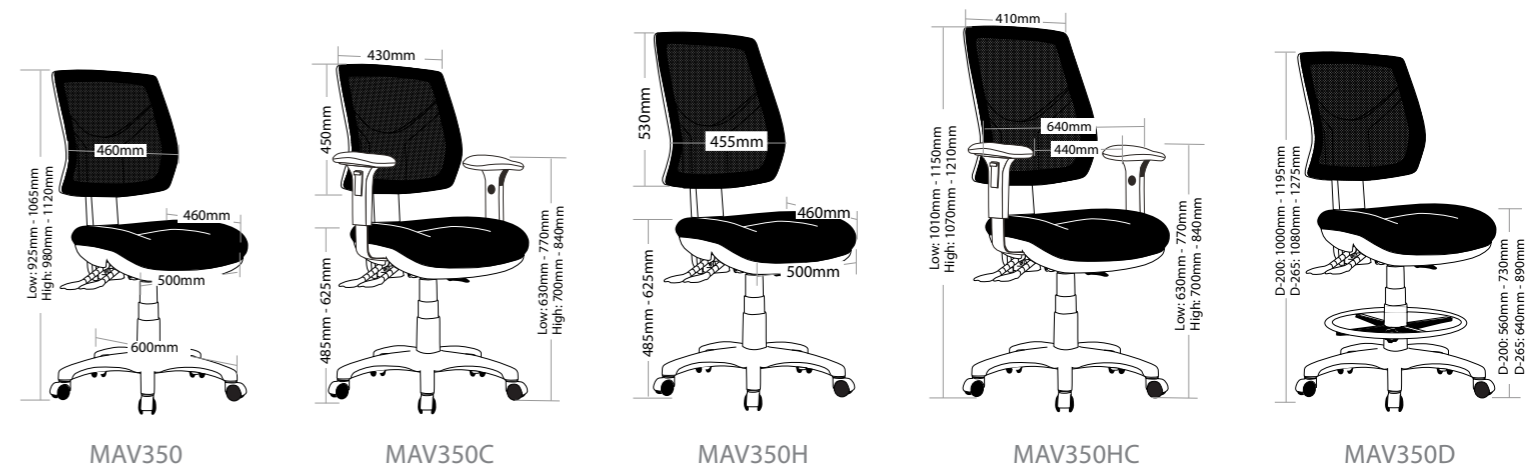

VESTA

TASK MESH SEATING



FEATURES

Adjustable seat height || Adjustable back height (ratchet) || Adjustable seat angle (with 3 lever mechanism only)
 Adjustable back angle || Optional adjustable arms || Optional seat depth (seat slider) (not available on drafting chair)
 Optional drafting kit || Optional 2 or 3 lever mechanism || Available in high and low back || Moulded seat foam
 Mesh back || Square seat || 660mm black nylon base || Available in local fabrics || Back mesh available in Jazz mesh
 AFRDI tested to level 6 || Suitable for indoor use only || 7 year warranty || Weight limit is 130kg



Blue Tick
Product
Certification

Approved by Furntech-AFRDI

*Check website www.furntech.org.au for current certification status

Certificate No.
18062/3
Nominal Expiry*
2 September 2028

Product name: **VESTA Mesh MVE350**
Low and High Back
Square Seat

Company: **Style Ergonomics Australia Pty Ltd**

Tested at: **Level 6 – Severe Commercial**

Tested for people up to 110 kg.

The Australasian Furnishing Research and Development Institute (AFRDI) hereby certify the above specified product under the AFRDI Blue Tick Product Certification Program using certification criteria based on **AS/NZS 4438:1997 (R2016) Height Adjustable Swivel Chairs**, and on additional requirements and variations as deemed appropriate by Furntech-AFRDI.

The company, identified above, has agreed to maintain the compliance of the product represented on this certificate, and to submit to retesting and auditing as appropriate.

NB. This product meets all of the strength, durability and stability requirements of the Standard but has some intentional variations to the requirements of the Functional Dimensions.

Testing and evaluation was conducted such that, in the opinion of Furntech-AFRDI, all products claiming AFRDI Approval that are assembled from the components designated on this certificate, should perform satisfactorily in relation to the certification criteria.

This certificate does not relate to fabrics or other upholstery coverings – chairs cannot comply with the Standard unless the fabrics or coverings used (if any) meet the flammability requirements of **AS/NZS 4088.1** and the care labelling requirements of **AS/NZS 1957**.

This certification is valid for three years but may be suspended, revoked or renewed.

Components	Identification
Arms: Height Adjustable	Style Vesta Arms
Mechanism	Style MECH 26
Seat Slider	No
Pedestal Base	Style BASE-8 Spider Base Style CONBAS Chrome Spider
Minimum Class of Gas Spring	Class 1
Gas Spring	Style GASSA
Castors: Friction	Style CAST11-OFF/SF Style CAST11-OFF/HF
Castors: Free Wheeling	Style CAST11 Black Castor
Foam: Seat	Style Moulded Foam
Mesh	Style Mesh



18062_3_251001_ct.docx

Australasian Furnishing Research & Development Institute Limited

ABN 44 009 579 908, trading as Furntech
 School Road (University Campus) Newnham Drive PO Box 2042 Launceston Tasmania 7250 Australia
 Tel (03) 6326 6155 Fax (03) 6326 3090
www.furntech.org.au Email: info@furntech.org.au



Standards, Testing and Product Certification for Commercial, Domestic and Nursery Furniture in Australia and New Zealand

INDOOR USE ONLY

✗ Do not use as a step ladder

To adjust back height hold back with two hands while seated and raise to desired height
 To lower the back height raise back all the way to the top and release slowly

OPTIONAL ADJUSTABLE ARMS

RIGHT BACK LEVER
To adjust back angle

RIGHT FRONT LEVER
To adjust seat height

LEFT LEVER
To adjust seat angle

660MM BLACK NYLON 5 STAR BASE WITH CASTORS

Use soft tyred castors for tiles
 Use hard tyred castors for carpet

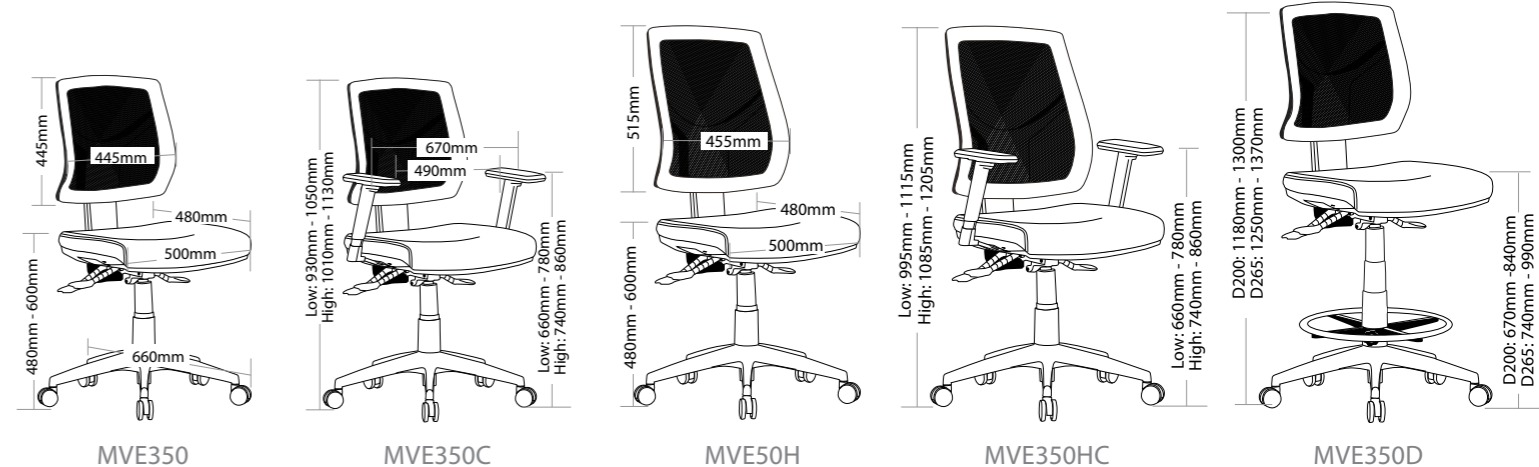
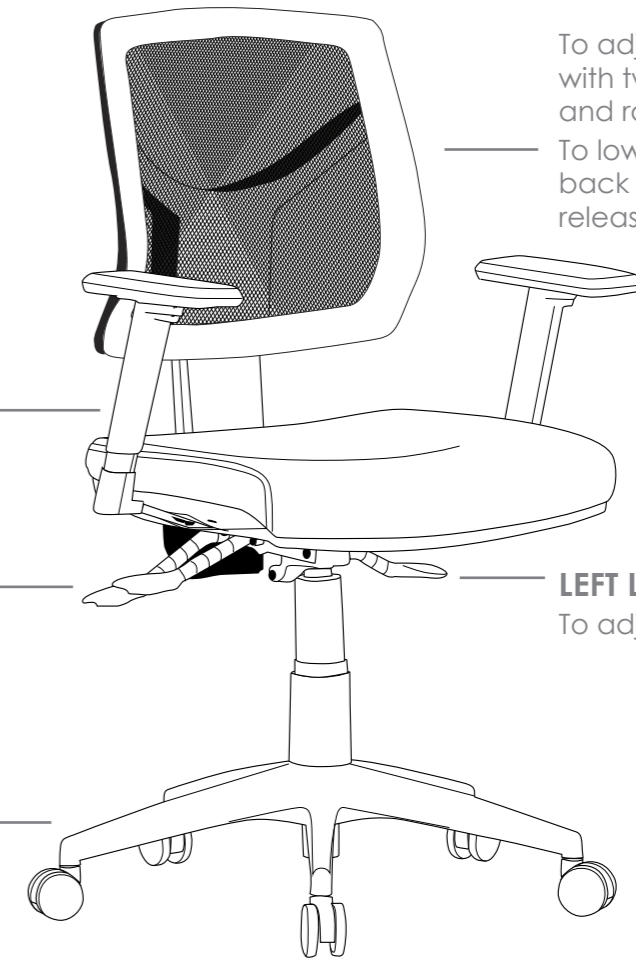

CHELSEA

TASK MESH SEATING



FEATURES

Adjustable seat height || Adjustable back height (ratchet) || Adjustable back and seat angle || Adjustable weight tension
 Adjustable seat depth (build-in seat slider)(available on MCH450L, MCH450H only) || Optional adjustable arms
 Optional seat depth (seat slider)(not available on drafting chair) || Optional drafting kit (not available on MCH450L, MCH450H)
 Available in high and low back || Moulded seat foam || Mesh back || Big boy seat || 3 lever ergonomic heavy duty mechanism
 700mm black nylon base || Available in local fabrics || Back mesh available in Jazz mesh || AFRDI tested to level 6
 Suitable for indoor use only || 7 year warranty || Weight limit is 140kg



MCH600L

MCH600HC

MCH600D

MCH450L

MCH450HC



Blue Tick
Product
Certification

Approved by Furntech-AFRDI
 *Check website www.furntech.org.au for current certification status

Certificate No.
18059/2
 Nominal Expiry*
2 September 2028

Product name: **Chelsea Mesh MCH600
 Low and High Back
 Large Seat**

Company: **Style Ergonomics Australia Pty Ltd**

Tested at: **Level 6 – Severe Commercial**

Tested for people up to 110 kg.

The Australasian Furnishing Research and Development Institute (AFRDI) hereby certify the above specified product under the AFRDI Blue Tick Product Certification Program using certification criteria based on **AS/NZS 4438:1997 (R2016) Height Adjustable Swivel Chairs**, and on additional requirements and variations as deemed appropriate by Furntech-AFRDI.

The company, identified above, has agreed to maintain the compliance of the product represented on this certificate, and to submit to retesting and auditing as appropriate.

NB. This product meets all of the strength, durability and stability requirements of the Standard but has some intentional variations to the requirements of the Functional Dimensions.

Testing and evaluation was conducted such that, in the opinion of Furntech-AFRDI, all products claiming AFRDI Approval that are assembled from the components designated on this certificate, should perform satisfactorily in relation to the certification criteria.

This certificate does not relate to fabrics or other upholstery coverings – chairs cannot comply with the Standard unless the fabrics or coverings used (if any) meet the flammability requirements of **AS/NZS 4088.1** and the care labelling requirements of **AS/NZS 1957**.

This certification is valid for three years but may be suspended, revoked or renewed.

Components	Identification
Arms: Height Adjustable	Style I-C Arms
Mechanism	Style MECH28
Seat Slider	No
Pedestal Base	Style BAS1-350 Black Base Style BAS4 Chrome Base
Minimum Class of Gas Spring	Class 2
Gas Spring	Style GAS2A
Castors: Friction	Style CAST1-OFF/SF Style CAST1-OFF/HF
Castors: Free Wheeling	Style CAST1 Black Castor
Foam: Seat	Style Moulded Foam
Foam: Back	Style Moulded Foam



18059-2_251013_ct.docx

Australasian Furnishing Research & Development Institute Limited
 ABN 44 009 579 908, trading as Furntech
 School Road (University Campus) Newnham Drive PO Box 2042 Launceston Tasmania 7250 Australia
 Tel (03) 6326 6155 Fax (03) 6326 3090
www.furntech.org.au Email: info@furntech.org.au



Standards, Testing and Product Certification for Commercial, Domestic and Nursery Furniture in Australia and New Zealand

INDOOR USE ONLY

✗ Do not use as a step ladder

OPTIONAL
ADJUSTABLE ARMS

RIGHT BACK LEVER
To adjust back angle

RIGHT MIDDLE LEVER
To adjust seat angle

RIGHT FRONT LEVER
To adjust seat height

700MM BLACK NYLON 5 STAR
BASE WITH CASTORS

Use soft tyred castors for tiles
Use hard tyred castors for carpet



To adjust back height hold back with two hands while seated and raise to desired height
 To lower the back height raise back all the way to the top and release slowly

LEFT LEVER
To adjust seat depth
(Build-in seat slider)

*ONLY AVAILABLE ON MCH450L/MCH450H

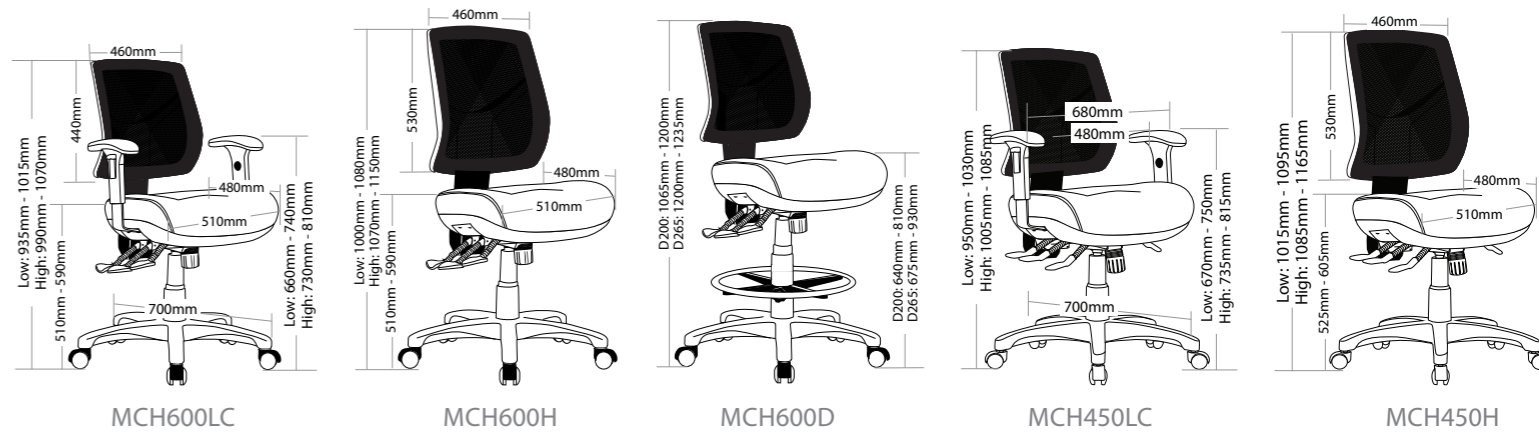

MCH600LC

MCH600H

MCH600D

MCH450LC

MCH450H

MEGA

TASK MESH SEATING



FEATURES

Adjustable seat height || Adjustable back height (ratchet) || Adjustable back and seat angle || Adjustable weight tension
 Optional adjustable arms || Moulded seat foam || Mega big boy seat || Mesh back
 Not available with drafting and seat slider || 3 lever ergonomic heavy duty mechanism || 700mm black nylon base
 Available in local fabrics || Back mesh available in Jazz mesh || AFRDI tested to level 6 || Suitable for indoor use only
 7 year warranty || Weight limit is 140kg



MEGA



MEGA-C



BACK VIEW



Blue Tick
Product
Certification

Approved by Furntech-AFRDI

*Check website www.furntech.org.au for current certification status

Certificate No.
18059/10
Nominal Expiry*
2 September 2028

Product name: **Mega & Mega-c High Back Extra Large Seat**
 Company: **Style Ergonomics Australia Pty Ltd**
 Tested at: **Level 6 – Severe Commercial**

Tested for people up to 110 kg.

The Australasian Furnishing Research and Development Institute (AFRDI) hereby certify the above specified product under the AFRDI Blue Tick Product Certification Program using certification criteria based on **AS/NZS 4438:1997 (R2016) Height Adjustable Swivel Chairs**, and on additional requirements and variations as deemed appropriate by Furntech-AFRDI.

The company, identified above, has agreed to maintain the compliance of the product represented on this certificate, and to submit to retesting and auditing as appropriate.

NB. This product meets all of the strength, durability and stability requirements of the Standard but has some intentional variations to the requirements of the Functional Dimensions.

Testing and evaluation was conducted such that, in the opinion of Furntech-AFRDI, all products claiming AFRDI Approval that are assembled from the components designated on this certificate, should perform satisfactorily in relation to the certification criteria.

This certificate does not relate to fabrics or other upholstery coverings – chairs cannot comply with the Standard unless the fabrics or coverings used (if any) meet the flammability requirements of **AS/NZS 4088.1** and the care labelling requirements of **AS/NZS 1957**.

This certification is valid for three years but may be suspended, revoked or renewed.

Components

Arms: Height Adjustable
 Mechanism
 Seat Slider
 Pedestal Base

Minimum Class of Gas Spring
 Gas Spring
 Castors: Friction

Castors: Free Wheeling
 Foam: Seat
 Foam: Back

Identification

Style I-C Arms
 Style MECH28
 No
 Style BAS1-350 Black Base
 Style BAS4 Chrome Base

Class 2
 Style GAS2A
 Style CAST1-OFF/SF
 Style CAST1-OFF/HF

Style CAST1 Black Castor
 Style Moulded Foam
 Style Moulded Foam



18059-10_251013_ct.docx

Australasian Furnishing Research & Development Institute Limited

ABN 44 009 579 908, trading as Furntech

School Road (University Campus) Newnham Drive PO Box 2042 Launceston Tasmania 7250 Australia

Tel (03) 6326 6155 Fax (03) 6326 3090

www.furntech.org.au Email: info@furntech.org.au



Standards, Testing and Product Certification for Commercial, Domestic and Nursery Furniture in Australia and New Zealand

INDOOR USE ONLY

X Do not use as a step ladder

OPTIONAL
ADJUSTABLE ARMS

RIGHT BACK LEVER
To adjust back angle

RIGHT MIDDLE LEVER
To adjust seat angle

RIGHT FRONT LEVER
To adjust seat height

700MM BLACK NYLON 5 STAR
BASE WITH CASTORS

Use soft tyred castors for tiles
 Use hard tyred castors for carpet

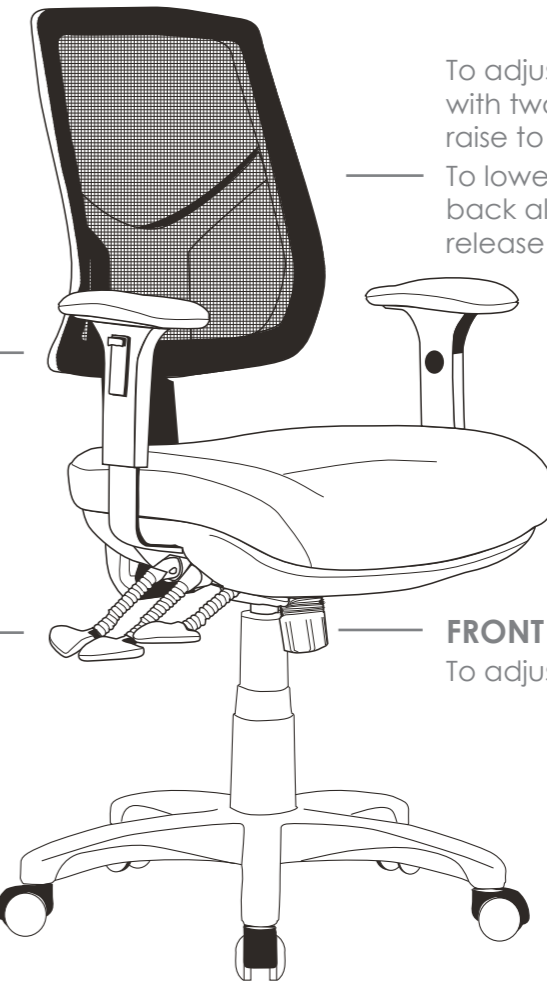

To adjust back height hold back with two hands while seated and raise to desired height
 To lower the back height raise back all the way to the top and release slowly

FRONT KNOB
To adjust weight tension

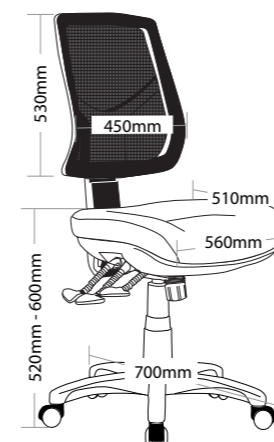

MEGA

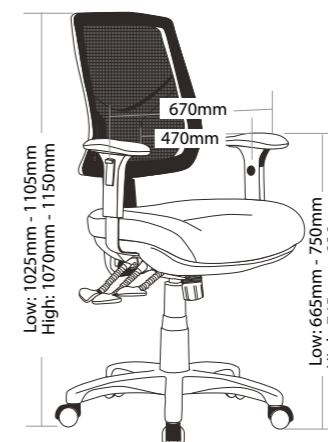

MEGA-C

PRESTIGE

TASK SEATING



FEATURES

Adjustable seat height || Adjustable back height || Adjustable seat angle (with 3 lever mechanism only)
 Adjustable back angle || Optional adjustable arms || Optional seat depth (seat slider) (not available on drafting chair)
 Optional drafting kit || Optional 2 or 3 lever mechanism || Available in high and low back || Moulded seat and back foam
 Java seat || 600mm black nylon base || Available in local fabrics || AFRDI tested to level 6 || Suitable for indoor use only
 7 year warranty || Weight limit is 130kg



Blue Tick
Product
Certification

Approved by Furntech-AFRDI

*Check website www.furntech.org.au for current certification status

Certificate No.
18062/1

Nominal Expiry*
2 September 2028

Product name: **Prestige P350**
Low and High Back
Standard and Square Seat

Company: **Style Ergonomics Australia Pty Ltd**

Tested at: **Level 6 – Severe Commercial**

Tested for people up to 110 kg.

The Australasian Furnishing Research and Development Institute (AFRDI) hereby certify the above specified product under the AFRDI Blue Tick Product Certification Program using certification criteria based on **AS/NZS 4438:1997 (R2016) Height Adjustable Swivel Chairs**, and on additional requirements and variations as deemed appropriate by Furntech-AFRDI.

The company, identified above, has agreed to maintain the compliance of the product represented on this certificate, and to submit to retesting and auditing as appropriate.

NB. This product meets all of the strength, durability and stability requirements of the Standard but has some intentional variations to the requirements of the Functional Dimensions.

Testing and evaluation was conducted such that, in the opinion of Furntech-AFRDI, all products claiming AFRDI Approval that are assembled from the components designated on this certificate, should perform satisfactorily in relation to the certification criteria.

This certificate does not relate to fabrics or other upholstery coverings – chairs cannot comply with the Standard unless the fabrics or coverings used (if any) meet the flammability requirements of **AS/NZS 4088.1** and the care labelling requirements of **AS/NZS 1957**.

This certification is valid for three years but may be suspended, revoked or renewed.

Components	Identification
Arms: Height Adjustable	Style I-C Arms Style Vesta Arms
Mechanism	Style MECH24 Style MECH26 Style MECH 2A
Seat Slider	No
Pedestal Base	Style BAS1-300 Black Base Style BAS1-350 Black Base Style Base-8 Spider Base Style CONBAS Chrome Spider Style BAS4 Chrome Base
Minimum Class of Gas Spring	Class 1
Gas Spring	Style GAS1A Style GASSA
Castors: Friction	Style CAST1-OFF/SF & HF Style CAST11-OFF/SF & HF
Castors: Free Wheeling	Style CAST1 Black Castor Style CAST 11 Black Castor
Foam: Seat	Style Moulded Foam
Foam: Back	Style Moulded Foam



18062-1_251001_ct.docx

Australasian Furnishing Research & Development Institute Limited

ABN 44 009 579 908, trading as Furntech

School Road (University Campus) Newnham Drive PO Box 2042 Launceston Tasmania 7250 Australia

Tel (03) 6326 6155 Fax (03) 6326 3090

www.furntech.org.au Email: info@furntech.org.au



Standards, Testing and Product Certification for Commercial, Domestic and Nursery Furniture in Australia and New Zealand

INDOOR USE ONLY

X Do not use as a step ladder

OPTIONAL
ADJUSTABLE ARMS

RIGHT BACK LEVER
To adjust back angle

RIGHT FRONT LEVER
To adjust seat height

600MM BLACK NYLON 5 STAR
BASE WITH CASTORS

Use soft tyred castors for tiles
Use hard tyred castors for carpet

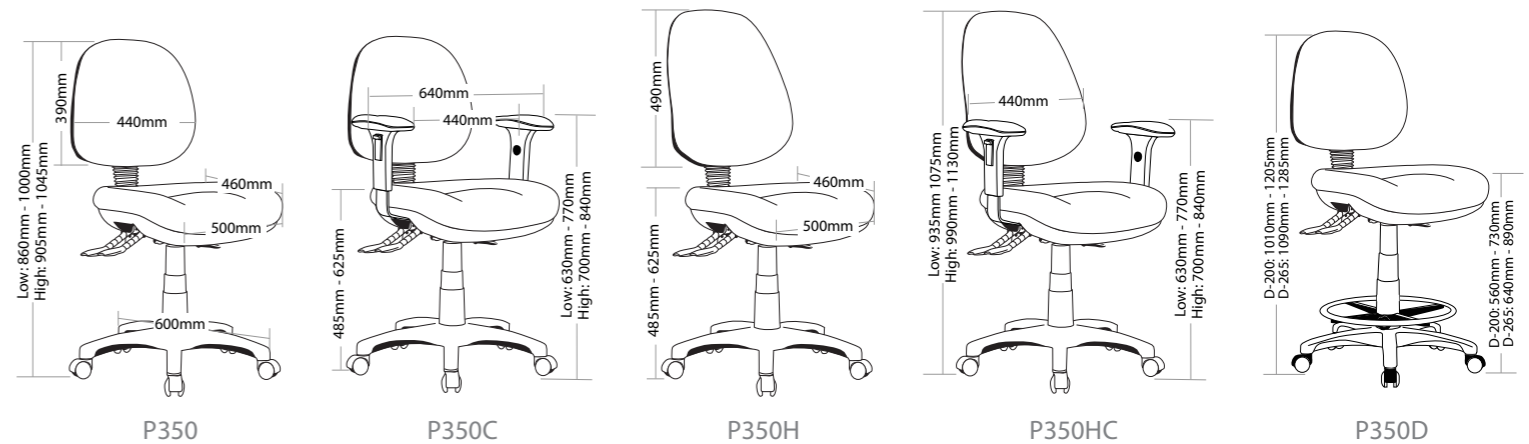
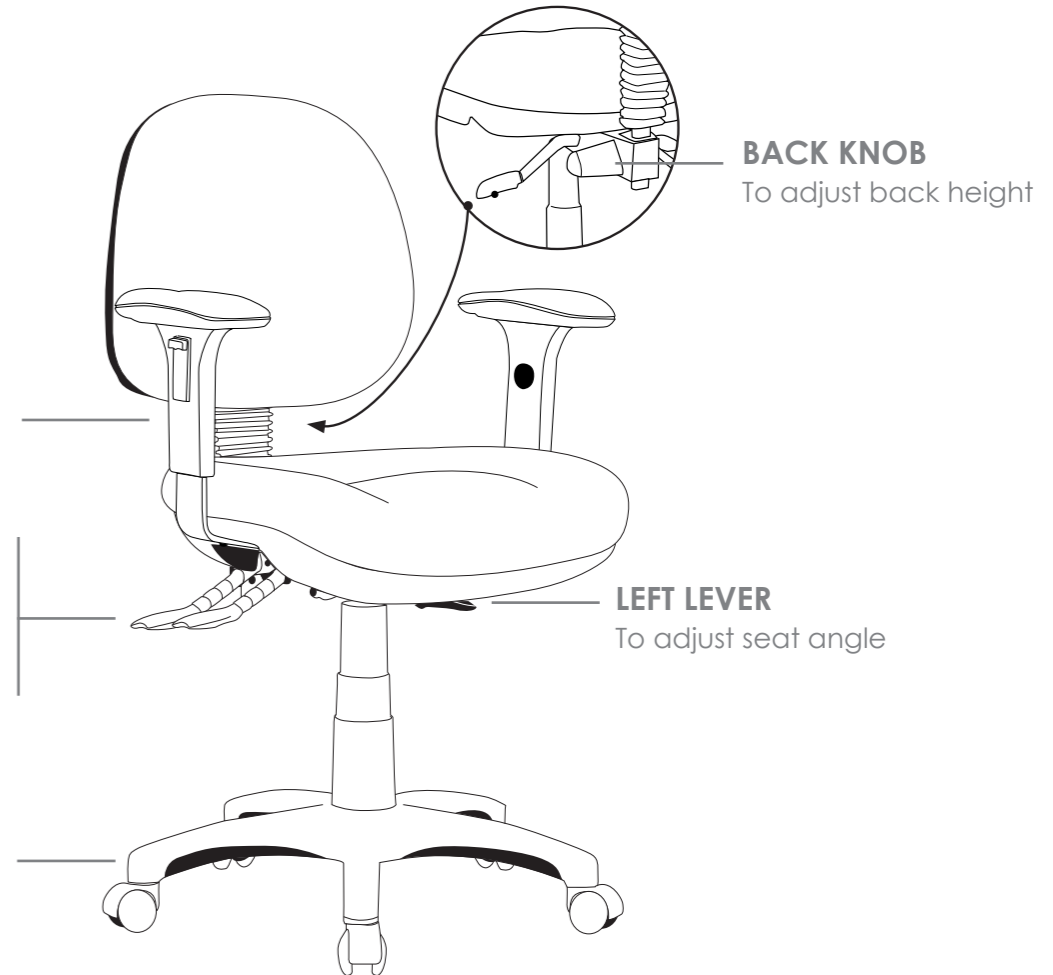

ORIEL

TASK SEATING



FEATURES

Adjustable seat height || Adjustable back height (ratchet) || Adjustable seat angle (with 3 lever mechanism only)
 Adjustable back angle || Optional adjustable arms || Optional seat depth (seat slider) (not available on drafting chair)
 Optional drafting kit || Optional 2 or 3 lever mechanism || Available in high and low back || Moulded seat and back foam
 Java seat || 600mm black nylon base || Available in local fabrics || AFRDI tested to level 6 || Suitable for indoor use only
 7 year warranty || Weight limit is 130kg



INDOOR USE ONLY

✗ Do not use as a step ladder

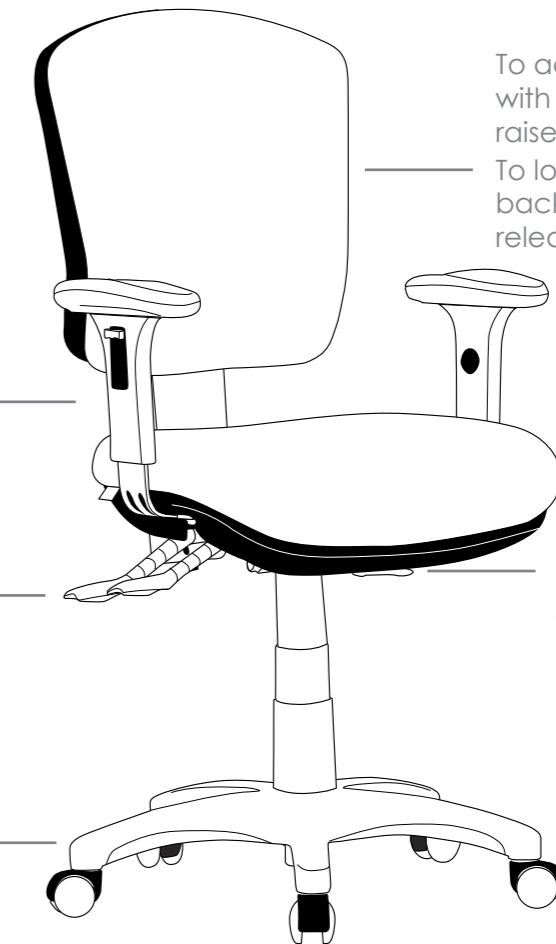

To adjust back height hold back with two hands while seated and raise to desired height
 To lower the back height raise back all the way to the top and release slowly

OPTIONAL ADJUSTABLE ARMS

RIGHT BACK LEVER
To adjust back angle

RIGHT FRONT LEVER
To adjust seat height

LEFT LEVER
To adjust seat angle

600MM BLACK NYLON 5 STAR BASE WITH CASTORS

Use soft tyred castors for tiles
 Use hard tyred castors for carpet

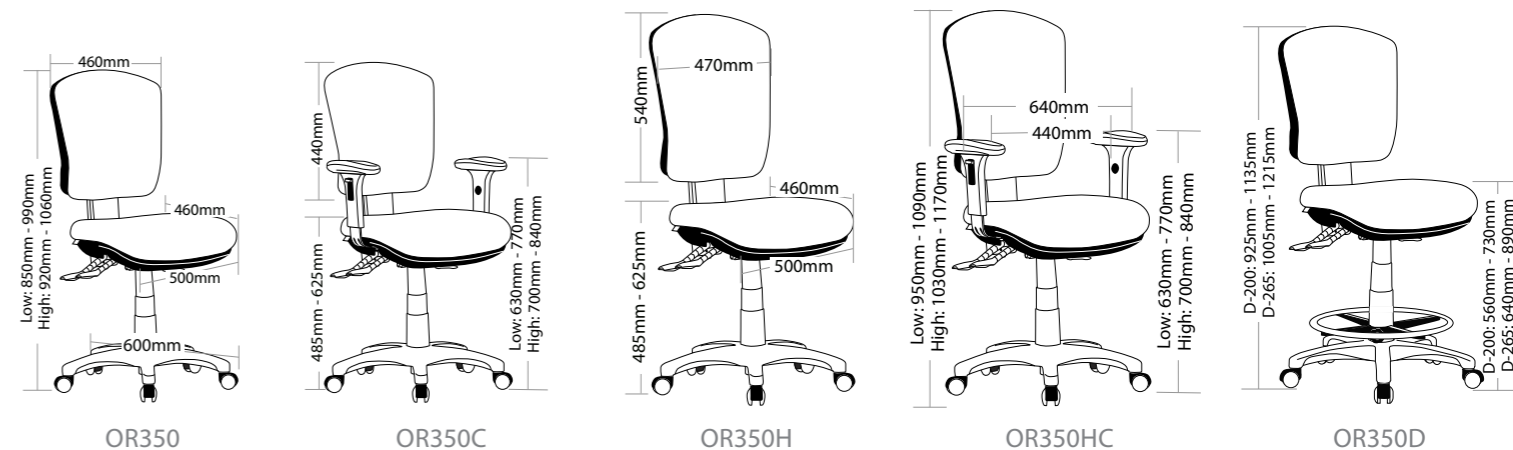

Blue Tick Product Certification

Approved by Furntech-AFRDI

*Check website www.furntech.org.au for current certification status

Certificate No. **18062/8**
 Nominal Expiry* **2 September 2028**

Product name: **Aqua & Oriel Chair Low and High Back Standard Seat**

Company: **Style Ergonomics Australia Pty Ltd**

Tested at: **Level 6 – Severe Commercial**

Tested for people up to 110 kg.

The Australasian Furnishing Research and Development Institute (AFRDI) hereby certify the above specified product under the AFRDI Blue Tick Product Certification Program using certification criteria based on **AS/NZS 4438:1997 (R2016) Height Adjustable Swivel Chairs**, and on additional requirements and variations as deemed appropriate by Furntech-AFRDI.

The company, identified above, has agreed to maintain the compliance of the product represented on this certificate, and to submit to retesting and auditing as appropriate.

NB. This product meets all of the strength, durability and stability requirements of the Standard but has some intentional variations to the requirements of the Functional Dimensions.

Testing and evaluation was conducted such that, in the opinion of Furntech-AFRDI, all products claiming AFRDI Approval that are assembled from the components designated on this certificate, should perform satisfactorily in relation to the certification criteria.

This certificate does not relate to fabrics or other upholstery coverings – chairs cannot comply with the Standard unless the fabrics or coverings used (if any) meet the flammability requirements of **AS/NZS 4088.1** and the care labelling requirements of **AS/NZS 1957**.

This certification is valid for three years but may be suspended, revoked or renewed.

Components	Identification
Arms: Height Adjustable	Style I-C Arms
Mechanism	Style MECH 26
Seat Slider	No
Pedestal Base	Style BAS1-300 Black Base Style BAS1-350 Black Base Style BAS4 Chrome Base
Minimum Class of Gas Spring	Class 1
Gas Spring	Style GAS1A
Castors: Friction	Style CAST11-OFF/SF Style CAST11-OFF/HF
Castors: Free Wheeling	Style CAST11 Black Castor
Foam: Seat	Style Moulded Foam
Foam: Back	Style Moulded Foam



18062-8_251001_ct.docx

Australasian Furnishing Research & Development Institute Limited

ABN 44 009 579 908, trading as Furntech
 School Road (University Campus) Newnham Drive PO Box 2042 Launceston Tasmania 7250 Australia
 Tel (03) 6326 6155 Fax (03) 6326 3090
www.furntech.org.au Email: info@furntech.org.au



Standards, Testing and Product Certification for Commercial, Domestic and Nursery Furniture in Australia and New Zealand

ALPHA

TASK SEATING



FEATURES

Adjustable seat height || Adjustable back height (ratchet) || Adjustable seat angle (with 3 lever mechanism only)
 Adjustable back angle || Optional adjustable arms || Optional seat depth (seat slider) (not available on drafting chair)
 Optional drafting kit || Optional 2 or 3 lever mechanism || Available in high and low back || Moulded seat and back foam
 Java seat || 600mm black nylon base || Available in local fabrics || AFRDI tested to level 6 || Suitable for indoor use only
 7 year warranty || Weight limit is 130kg



AL350

AL350C

AL350H

AL350HC

AL350D



Blue Tick
Product
Certification

Approved by Furntech-AFRDI

*Check website www.furntech.org.au for current certification status

Certificate No.
18062/5
Nominal Expiry*
2 September 2028

Product name: **Alpha AL350
Low and High Back
Standard Seat**

Company: **Style Ergonomics Australia Pty Ltd**

Tested at: **Level 6 – Severe Commercial**

Tested for people up to 110 kg.

The Australasian Furnishing Research and Development Institute (AFRDI) hereby certify the above specified product under the AFRDI Blue Tick Product Certification Program using certification criteria based on **AS/NZS 4438:1997 (R2016) Height Adjustable Swivel Chairs**, and on additional requirements and variations as deemed appropriate by Furntech-AFRDI.

The company, identified above, has agreed to maintain the compliance of the product represented on this certificate, and to submit to retesting and auditing as appropriate.

NB. This product meets all of the strength, durability and stability requirements of the Standard but has some intentional variations to the requirements of the Functional Dimensions.

Testing and evaluation was conducted such that, in the opinion of Furntech-AFRDI, all products claiming AFRDI Approval that are assembled from the components designated on this certificate, should perform satisfactorily in relation to the certification criteria.

This certificate does not relate to fabrics or other upholstery coverings – chairs cannot comply with the Standard unless the fabrics or coverings used (if any) meet the flammability requirements of **AS/NZS 4088.1** and the care labelling requirements of **AS/NZS 1957**.

This certification is valid for three years but may be suspended, revoked or renewed.

Components

Arms: Height Adjustable
Mechanism
Seat Slider
Pedestal Base

Identification

Style I-C Arms
Style MECH 26
No
Style BAS1-300 Black Base
Style BAS1-350 Black Base
Style BAS4 Chrome Base
Class 1
Style GAS1A
Style CAST11-OFF/SF
Style CAST11-OFF/HF
Style CAST11 Black Castor
Style Moulded Foam
Style Moulded Foam



18062-5_251001_ct.docx

Australasian Furnishing Research & Development Institute Limited

ABN 44 009 579 908, trading as Furntech

School Road (University Campus) Newnham Drive PO Box 2042 Launceston Tasmania 7250 Australia

Tel (03) 6326 6155 Fax (03) 6326 3090

www.furntech.org.au Email: info@furntech.org.au



Standards, Testing and Product Certification for Commercial, Domestic and Nursery Furniture in Australia and New Zealand

INDOOR USE ONLY

X Do not use as a step ladder

OPTIONAL
ADJUSTABLE ARMS

RIGHT BACK LEVER
To adjust back angle

RIGHT FRONT LEVER
To adjust seat height

600MM BLACK NYLON 5 STAR
BASE WITH CASTORS

Use soft tyred castors for tiles
Use hard tyred castors for carpet

To adjust back height hold back with two hands while seated and raise to desired height

To lower the back height raise back all the way to the top and release slowly

LEFT LEVER
To adjust seat angle

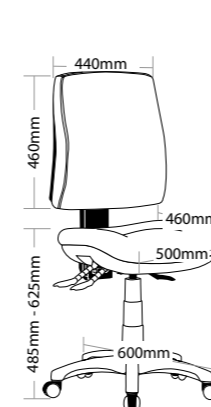
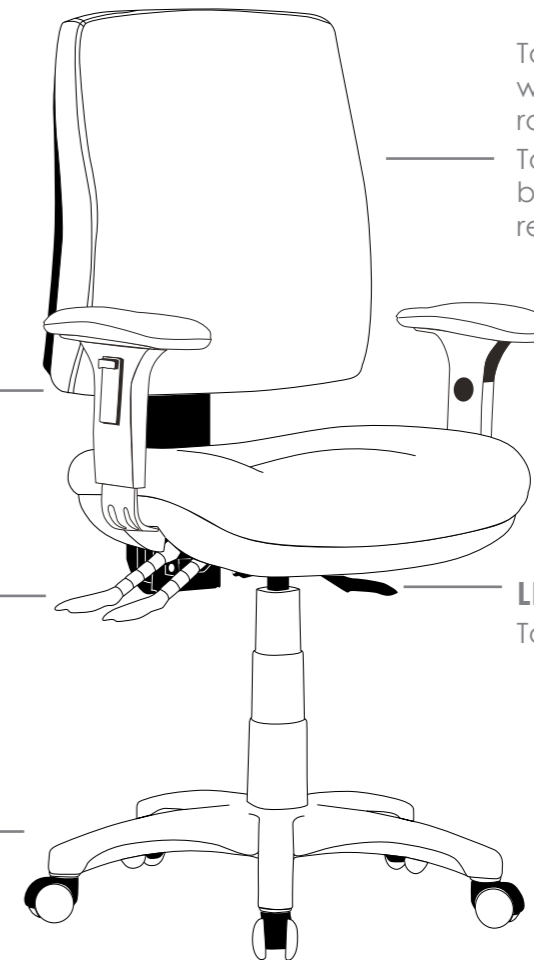

AL350

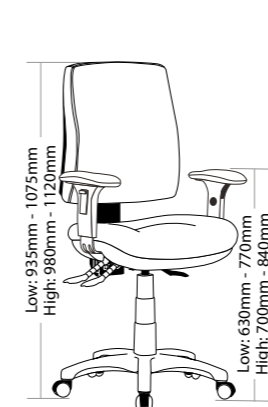

AL350C

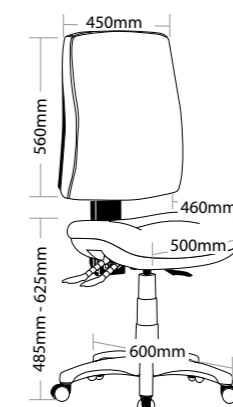

AL350H

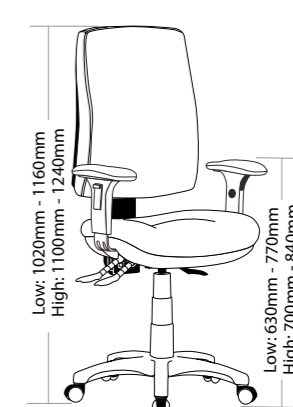

AL350HC

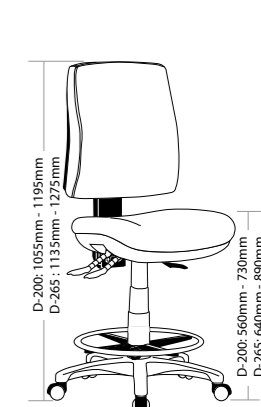

AL350D

VIRGO

TASK SEATING



FEATURES

Adjustable seat height || Adjustable back height (ratchet) || Adjustable seat angle (with 3 lever mechanism only)
 Adjustable back angle || Optional adjustable arms || Optional seat depth (seat slider) (not available on drafting chair)
 Optional drafting kit || Optional 2 or 3 lever mechanism || Available in high and low back || Moulded seat and back foam
 Square seat || 660mm black nylon base || Available in local fabrics || AFRDI tested to level 6 || Suitable for indoor use only
 7 year warranty || Weight limit is 130kg



VI350

VI350C

VI350H

VI350HC

VI350D



Blue Tick
Product
Certification

Approved by Furntech-AFRDI

*Check website www.furntech.org.au for current certification status

Certificate No.
18062/7

Nominal Expiry*
2 September 2028

Product name: **Virgo VI350**
Low and High Back
Square Seat

Company: **Style Ergonomics Australia Pty Ltd**

Tested at: **Level 6 – Severe Commercial**

Tested for people up to 110 kg.

The Australasian Furnishing Research and Development Institute (AFRDI) hereby certify the above specified product under the AFRDI Blue Tick Product Certification Program using certification criteria based on **AS/NZS 4438:1997 (R2016) Height Adjustable Swivel Chairs**, and on additional requirements and variations as deemed appropriate by Furntech-AFRDI.

The company, identified above, has agreed to maintain the compliance of the product represented on this certificate, and to submit to retesting and auditing as appropriate.

NB. This product meets all of the strength, durability and stability requirements of the Standard but has some intentional variations to the requirements of the Functional Dimensions.

Testing and evaluation was conducted such that, in the opinion of Furntech-AFRDI, all products claiming AFRDI Approval that are assembled from the components designated on this certificate, should perform satisfactorily in relation to the certification criteria.

This certificate does not relate to fabrics or other upholstery coverings – chairs cannot comply with the Standard unless the fabrics or coverings used (if any) meet the flammability requirements of **AS/NZS 4088.1** and the care labelling requirements of **AS/NZS 1957**.

This certification is valid for three years but may be suspended, revoked or renewed.

Components	Identification
Arms: Height Adjustable	Style Vesta Arm
Mechanism	Style MECH 26
Seat Slider	No
Pedestal Base	Style Base-8 Spider Base Style CONBAS Chrome Spider
Minimum Class of Gas Spring	Class 1
Gas Spring	Style GASSA
Castors: Friction	Style CAST11-OFF/SF Style CAST11-OFF/HF
Castors: Free Wheeling	Style CAST11 Black Castor
Foam: Seat	Style Moulded Foam
Foam: Back	Style Moulded Foam



18062-7_251001_ct.docx

Australasian Furnishing Research & Development Institute Limited

ABN 44 009 579 908, trading as Furntech
 School Road (University Campus) Newnham Drive PO Box 2042 Launceston Tasmania 7250 Australia
 Tel (03) 6326 6155 Fax (03) 6326 3090
www.furntech.org.au Email: info@furntech.org.au



Standards, Testing and Product Certification for Commercial, Domestic and Nursery Furniture in Australia and New Zealand

INDOOR USE ONLY

✗ Do not use as a step ladder

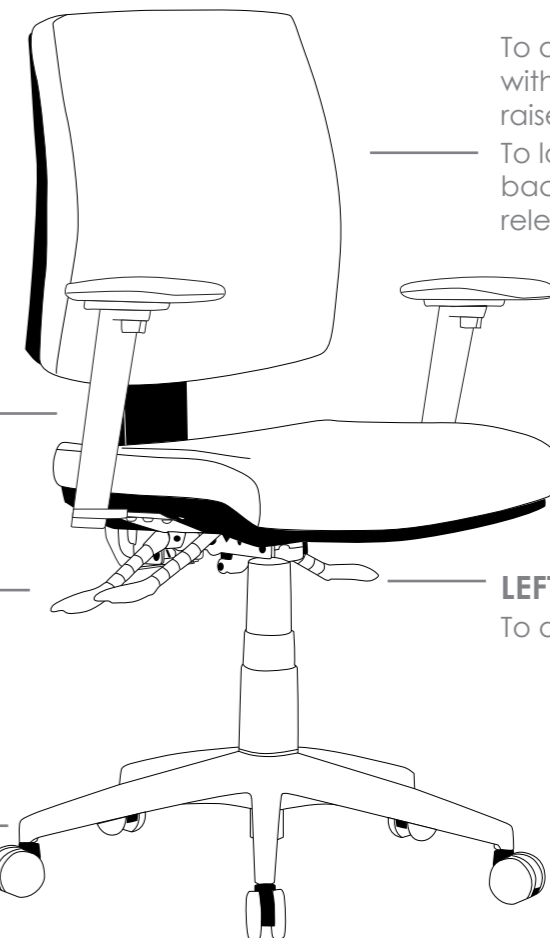

To adjust back height hold back with two hands while seated and raise to desired height
 To lower the back height raise back all the way to the top and release slowly

OPTIONAL
ADJUSTABLE ARMS

RIGHT BACK LEVER
To adjust back angle

RIGHT FRONT LEVER
To adjust seat height

LEFT LEVER
To adjust seat angle

660MM BLACK NYLON 5 STAR BASE WITH CASTORS

Use soft tyred castors for tiles
 Use hard tyred castors for carpet

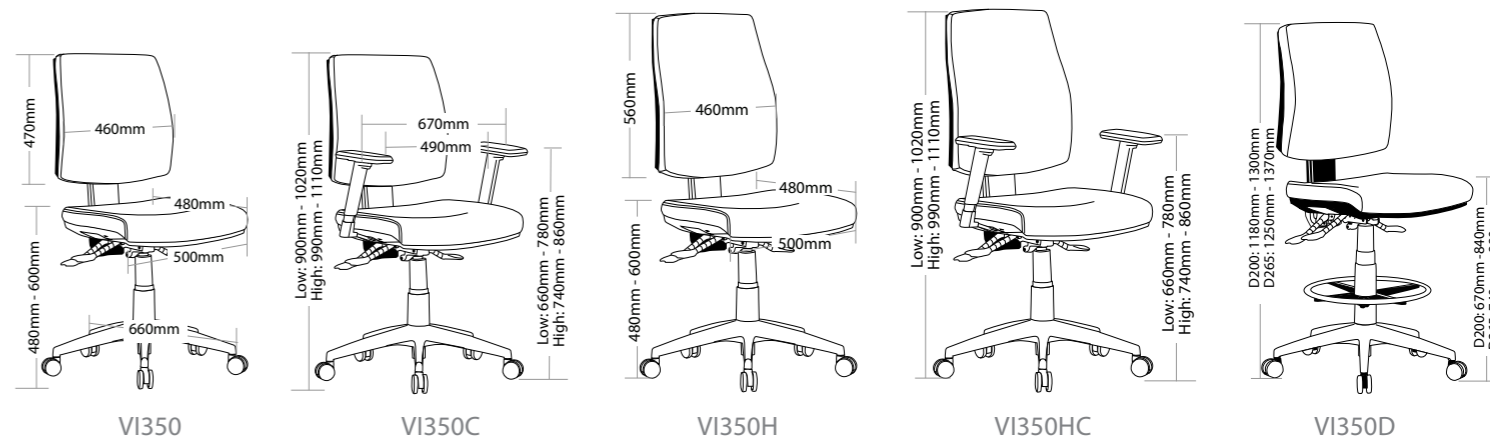

VI350

VI350C

VI350H

VI350HC

VI350D

GALAXY

TASK SEATING



FEATURES

Adjustable seat height || Adjustable back height (ratchet) || Adjustable back and seat angle || Adjustable weight tension
 Adjustable seat depth (build-in seat slider)(available on GA450L, GA450H only) || Optional adjustable arms
 Optional seat depth (seat slider)(not available on drafting chair) || Optional drafting kit (not available on GA450L, GA450H)
 Available in high and low back || Moulded seat and back foam || Big boy seat || 3 lever ergonomic heavy duty mechanism
 700mm black nylon base || Available in local fabrics || AFRDI tested to level 6 || Suitable for indoor use only
 7 year warranty || Weight limit is 140kg



GA600L GA600HC GA600LD GA450L GA450HC



Blue Tick
Product
Certification

Approved by Furntech-AFRDI

*Check website www.furntech.org.au for current certification status

Certificate No.
18059/1

Nominal Expiry*
2 September 2028

Product name: **Galaxy GA600**
Low and High Back
Large and Extra Large Seat

Company: **Style Ergonomics Australia Pty Ltd**

Tested at: **Level 6 – Severe Commercial**

Tested for people up to 110 kg.

The Australasian Furnishing Research and Development Institute (AFRDI) hereby certify the above specified product under the AFRDI Blue Tick Product Certification Program using certification criteria based on **AS/NZS 4438:1997 (R2016) Height Adjustable Swivel Chairs**, and on additional requirements and variations as deemed appropriate by Furntech-AFRDI.

The company, identified above, has agreed to maintain the compliance of the product represented on this certificate, and to submit to retesting and auditing as appropriate.

NB. This product meets all of the strength, durability and stability requirements of the Standard but has some intentional variations to the requirements of the Functional Dimensions.

Testing and evaluation was conducted such that, in the opinion of Furntech-AFRDI, all products claiming AFRDI Approval that are assembled from the components designated on this certificate, should perform satisfactorily in relation to the certification criteria.

This certificate does not relate to fabrics or other upholstery coverings – chairs cannot comply with the Standard unless the fabrics or coverings used (if any) meet the flammability requirements of **AS/NZS 4088.1** and the care labelling requirements of **AS/NZS 1957**.

This certification is valid for three years but may be suspended, revoked or renewed.

Components	Identification
Arms: Height Adjustable	Style I-C Arms
Mechanism	Style MECH28
Seat Slider	No
Pedestal Base	Style BAS1-350 Black Base Style BAS4 Chrome Base
Minimum Class of Gas Spring	Class 2
Gas Spring	Style GAS2A
Castors: Friction	Style CAST1-OFF/SF Style CAST1-OFF/HF
Castors: Free Wheeling	Style CAST1 Black Castor
Foam: Seat	Style Moulded Foam
Foam: Back	Style Moulded Foam



18059-1_251013_ct.docx

Australasian Furnishing Research & Development Institute Limited

ABN 44 009 579 908, trading as Furntech

School Road (University Campus) Newnham Drive PO Box 2042 Launceston Tasmania 7250 Australia

Tel (03) 6326 6155 Fax (03) 6326 3090

www.furntech.org.au Email: info@furntech.org.au



Standards, Testing and Product Certification for Commercial, Domestic and Nursery Furniture in Australia and New Zealand

INDOOR USE ONLY

✗ Do not use as a step ladder

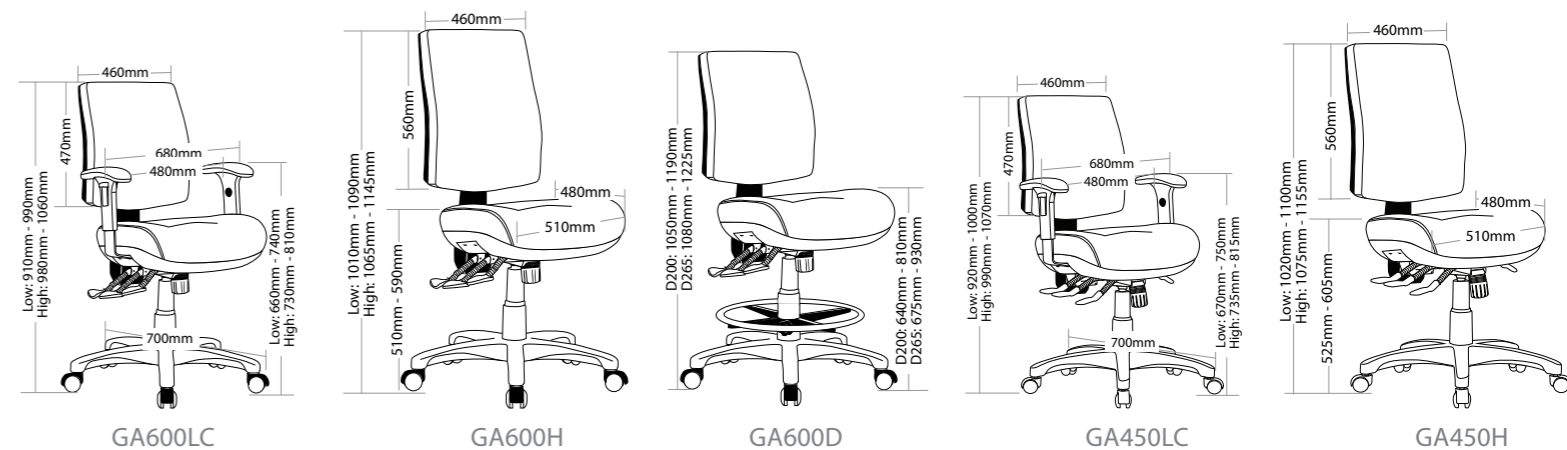
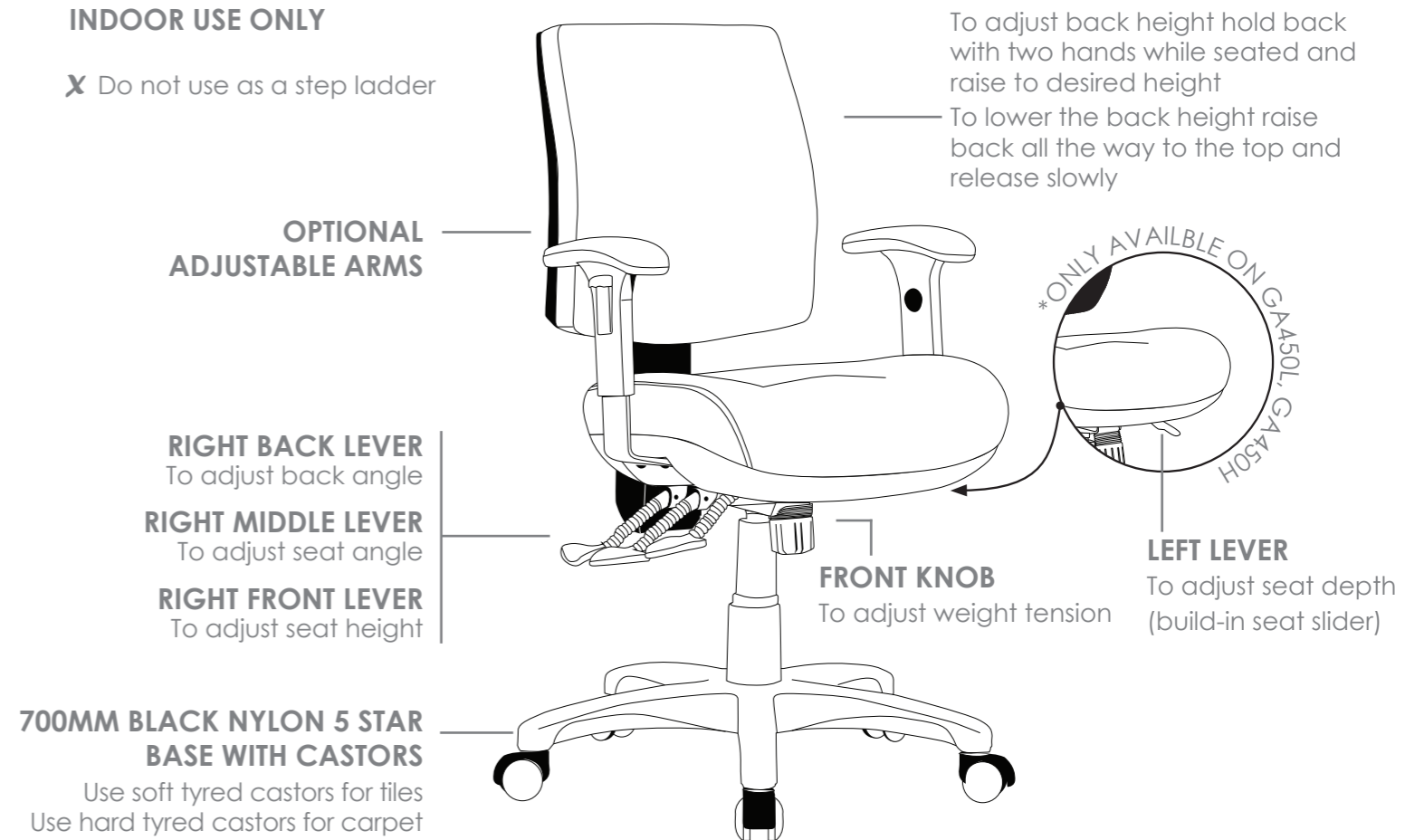

PROFILE

TASK SEATING



FEATURES

Adjustable seat height || Adjustable back height (ratchet) || Adjustable back and seat angle || Adjustable weight tension
 Optional adjustable arms || Optional seat depth (seat slider)(not available on drafting chair) || Optional drafting kit
 Available in high and low back || Moulded seat and back foam || Big boy seat || 3 lever ergonomic heavy duty mechanism
 700mm black nylon base || Available in local fabrics || AFRDI tested to level 6 || Suitable for indoor use only
 7 year warranty || Weight limit is 140kg



PR600



PR600C



PR600D



Blue Tick
Product
Certification

Approved by Furntech-AFRDI

*Check website www.furntech.org.au for current certification status

Certificate No.
18059/4

Nominal Expiry*
2 September 2028

Product name: **Prestige PR600
High Back
Large Seat**

Company: **Style Ergonomics Australia Pty Ltd**

Tested at: **Level 6 – Severe Commercial**

Tested for people up to 110 kg.

The Australasian Furnishing Research and Development Institute (AFRDI) hereby certify the above specified product under the AFRDI Blue Tick Product Certification Program using certification criteria based on **AS/NZS 4438:1997 (R2016) Height Adjustable Swivel Chairs**, and on additional requirements and variations as deemed appropriate by Furntech-AFRDI.

The company, identified above, has agreed to maintain the compliance of the product represented on this certificate, and to submit to retesting and auditing as appropriate.

NB. This product meets all of the strength, durability and stability requirements of the Standard but has some intentional variations to the requirements of the Functional Dimensions.

Testing and evaluation was conducted such that, in the opinion of Furntech-AFRDI, all products claiming AFRDI Approval that are assembled from the components designated on this certificate, should perform satisfactorily in relation to the certification criteria.

This certificate does not relate to fabrics or other upholstery coverings – chairs cannot comply with the Standard unless the fabrics or coverings used (if any) meet the flammability requirements of **AS/NZS 4088.1** and the care labelling requirements of **AS/NZS 1957**.

This certification is valid for three years but may be suspended, revoked or renewed.

Components	Identification
Arms: Height Adjustable	Style I-C Arms
Mechanism	Style MECH28
Seat Slider	No
Pedestal Base	Style BAS1-350 Black Base Style BAS4 Chrome Base
Minimum Class of Gas Spring	Class 2
Gas Spring	Style GAS2A
Castors: Friction	Style CAST1-OFF/SF Style CAST1-OFF/HF
Castors: Free Wheeling	Style CAST1 Black Castor
Foam: Seat	Style Moulded Foam
Foam: Back	Style Moulded Foam



18059-4_251013_ct.docx

Australasian Furnishing Research & Development Institute Limited
 ABN 44 009 579 908, trading as Furntech
 School Road (University Campus) Newnham Drive PO Box 2042 Launceston Tasmania 7250 Australia
 Tel (03) 6326 6155 Fax (03) 6326 3090
www.furntech.org.au Email: info@furntech.org.au



Standards, Testing and Product Certification for Commercial, Domestic and Nursery Furniture in Australia and New Zealand

INDOOR USE ONLY

✗ Do not use as a step ladder

To adjust back height hold back with two hands while seated and raise to desired height
 To lower the back height raise back all the way to the top and release slowly

OPTIONAL
ADJUSTABLE ARMS

RIGHT BACK LEVER
To adjust back angle

RIGHT MIDDLE LEVER
To adjust seat angle

RIGHT FRONT LEVER
To adjust seat height

FRONT KNOB
To adjust weight tension

700MM BLACK NYLON 5 STAR
BASE WITH CASTORS

Use soft tyred castors for tiles
Use hard tyred castors for carpet

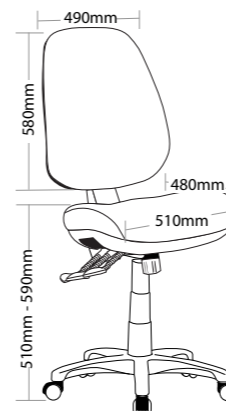

PR600

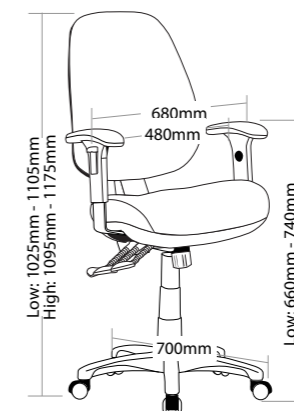

PR600C

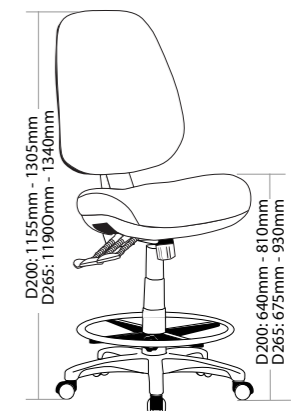

PR600D

EPIC

TASK SEATING



FEATURES

Adjustable seat height || Adjustable back height (ratchet) || Adjustable back and seat angle || Adjustable weight tension
 Optional adjustable arms || Moulded seat and back foam || Mega big boy seat || Not available with drafting and seat slider
 3 lever ergonomic heavy duty mechanism || 700mm black nylon base || Available in local fabrics || AFRDI tested to level 6
 Suitable for indoor use only || 7 year warranty || Weight limit is 140kg



EPIC



EPIC-C



BACK VIEW



Blue Tick
Product
Certification

Approved by Furntech-AFRDI

*Check website www.furntech.org.au for current certification status

Certificate No.
18059/9

Nominal Expiry*
2 September 2028

Product name: **Epic & Epic-C
High Back
Extra Large Seat**

Company: **Style Ergonomics Australia Pty Ltd**

Tested at: **Level 6 – Severe Commercial**

Tested for people up to 110 kg.

The Australasian Furnishing Research and Development Institute (AFRDI) hereby certify the above specified product under the AFRDI Blue Tick Product Certification Program using certification criteria based on **AS/NZS 4438:1997 (R2016) Height Adjustable Swivel Chairs**, and on additional requirements and variations as deemed appropriate by Furntech-AFRDI.

The company, identified above, has agreed to maintain the compliance of the product represented on this certificate, and to submit to retesting and auditing as appropriate.

NB. This product meets all of the strength, durability and stability requirements of the Standard but has some intentional variations to the requirements of the Functional Dimensions.

Testing and evaluation was conducted such that, in the opinion of Furntech-AFRDI, all products claiming AFRDI Approval that are assembled from the components designated on this certificate, should perform satisfactorily in relation to the certification criteria.

This certificate does not relate to fabrics or other upholstery coverings – chairs cannot comply with the Standard unless the fabrics or coverings used (if any) meet the flammability requirements of **AS/NZS 4088.1** and the care labelling requirements of **AS/NZS 1957**.

This certification is valid for three years but may be suspended, revoked or renewed.

Components	Identification
Arms: Height Adjustable	Style I-C Arms
Mechanism	Style MECH28
Seat Slider	No
Pedestal Base	Style BAS1-350 Black Base Style BAS4 Chrome Base
Minimum Class of Gas Spring	Class 2
Gas Spring	Style GAS2A
Castors: Friction	Style CAST1-OFF/SF Style CAST1-OFF/HF
Castors: Free Wheeling	Style CAST1 Black Castor
Foam: Seat	Style Moulded Foam
Foam: Back	Style Moulded Foam



18059-9_251013_ct.docx



Standards, Testing and Product Certification for Commercial, Domestic and Nursery Furniture in Australia and New Zealand

Australasian Furnishing Research & Development Institute Limited
 ABN 44 099 579 908, trading as Furntech
 School Road (University Campus) Newnham Drive PO Box 2042 Launceston Tasmania 7250 Australia
 Tel (03) 6326 6155 Fax (03) 6326 3090
 www.furntech.org.au Email: info@furntech.org.au

INDOOR USE ONLY

X Do not use as a step ladder

To adjust back height hold back with two hands while seated and raise to desired height
 To lower the back height raise back all the way to the top and release slowly

OPTIONAL ADJUSTABLE ARMS

RIGHT BACK LEVER
To adjust back angle

RIGHT MIDDLE LEVER
To adjust seat angle

RIGHT FRONT LEVER
To adjust seat height

FRONT KNOB
To adjust weight tension

700MM BLACK NYLON 5 STAR BASE WITH CASTORS

Use soft tyred castors for tiles
 Use hard tyred castors for carpet

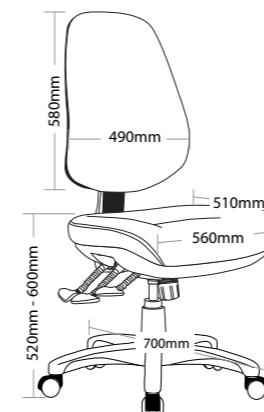

EPIC

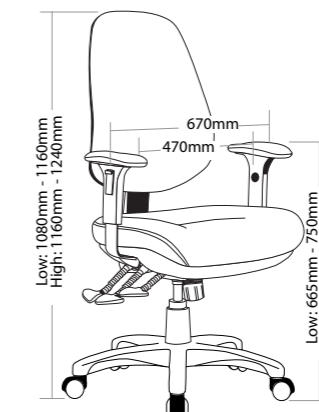

EPIC-C

SPIRAL TASK SEATING



FEATURES

Adjustable seat height || Adjustable back height (ratchet) || Adjustable back and seat angle || Adjustable weight tension
 Optional adjustable arms || Moulded seat and back foam || Mega big boy seat || Not available with drafting and seat slider
 3 lever ergonomic heavy duty mechanism || 700mm black nylon base || Available in local fabrics || AFRDI tested to level 6
 Suitable for indoor use only || 7 year warranty || Weight limit is 140kg



SPIRAL



SPIRAL-C



BACK VIEW



Blue Tick
Product
Certification

Approved by Furntech-AFRDI

*Check website www.furntech.org.au for current certification status

Certificate No.
18059/8

Nominal Expiry*
2 September 2028

Product name: **Spiral & Spiral-C
High Back
Extra Large Seat**

Company: **Style Ergonomics Australia Pty Ltd**

Tested at: **Level 6 – Severe Commercial**

Tested for people up to 110 kg.

The Australasian Furnishing Research and Development Institute (AFRDI) hereby certify the above specified product under the AFRDI Blue Tick Product Certification Program using certification criteria based on **AS/NZS 4438:1997 (R2016) Height Adjustable Swivel Chairs**, and on additional requirements and variations as deemed appropriate by Furntech-AFRDI.

The company, identified above, has agreed to maintain the compliance of the product represented on this certificate, and to submit to retesting and auditing as appropriate.

NB. This product meets all of the strength, durability and stability requirements of the Standard but has some intentional variations to the requirements of the Functional Dimensions.

Testing and evaluation was conducted such that, in the opinion of Furntech-AFRDI, all products claiming AFRDI Approval that are assembled from the components designated on this certificate, should perform satisfactorily in relation to the certification criteria.

This certificate does not relate to fabrics or other upholstery coverings – chairs cannot comply with the Standard unless the fabrics or coverings used (if any) meet the flammability requirements of **AS/NZS 4088.1** and the care labelling requirements of **AS/NZS 1957**.

This certification is valid for three years but may be suspended, revoked or renewed.

Components	Identification
Arms: Height Adjustable	Style I-C Arms
Mechanism	Style MECH28
Seat Slider	No
Pedestal Base	Style BAS1-350 Black Base Style BAS4 Chrome Base
Minimum Class of Gas Spring	Class 2
Gas Spring	Style GAS2A
Castors: Friction	Style CAST1-OFF/SF Style CAST1-OFF/HF
Castors: Free Wheeling	Style CAST1 Black Castor
Foam: Seat	Style Moulded Foam
Foam: Back	Style Moulded Foam



18059-8_251013_ct.docx



Standards, Testing and Product Certification for Commercial, Domestic and Nursery Furniture in Australia and New Zealand

Australasian Furnishing Research & Development Institute Limited
 ABN 44 099 579 908, trading as Furntech
 School Road (University Campus) Newnham Drive PO Box 2042 Launceston Tasmania 7250 Australia
 Tel (03) 6326 6155 Fax (03) 6326 3090
www.furntech.org.au Email: info@furntech.org.au

INDOOR USE ONLY

✗ Do not use as a step ladder

OPTIONAL ADJUSTABLE ARMS

RIGHT BACK LEVER
To adjust back angle

RIGHT MIDDLE LEVER
To adjust seat angle

RIGHT FRONT LEVER
To adjust seat height

700MM BLACK NYLON 5 STAR BASE WITH CASTORS

Use soft tyred castors for tiles
Use hard tyred castors for carpet

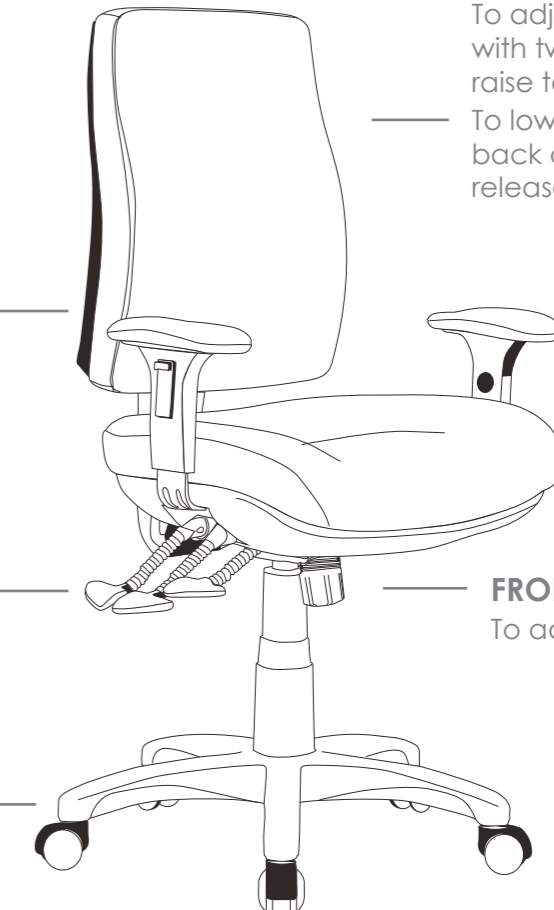

To adjust back height hold back with two hands while seated and raise to desired height
 To lower the back height raise back all the way to the top and release slowly

FRONT KNOB
To adjust weight tension

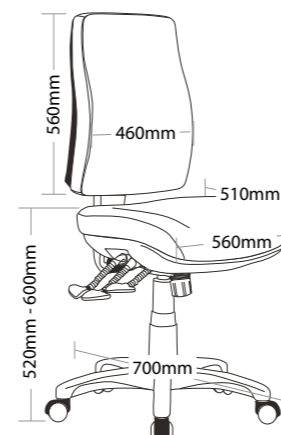

SPIRAL

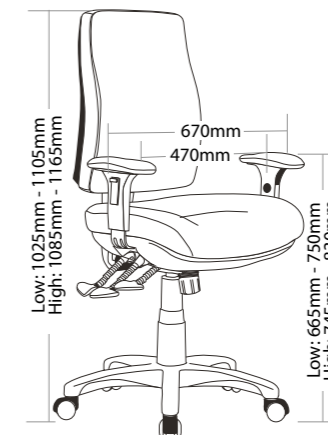

SPIRAL-C

DUELER

MULTI SHIFT SEATING



FEATURES

Adjustable seat height || Adjustable seat and back angle || Forward tilt adjustment || Adjustable seat depth (seat slider)
 Adjustable weight tension || Adjustable headrest || Adjustable arms || Moulded seat and back foam || Saddle seat
 Synchron mechanism with 3 locking positions || 720mm aluminium base || Brake castors || Available in local fabrics
 AFRDI tested to level 6 || AFRDI tested to multi shift use 160kg || Suitable for indoor use only
 7 year warranty || Weight limit is 160kg



DUELER



SIDE VIEW



BACK VIEW



Approved by Furntech-AFRDI

*Check website www.furntech.org.au for current certification status

Certificate No.
17283/5

Nominal Expiry*
13 February 2027

RATED LOAD

Blue Tick
Product
Certification

Product name: **Dueler Chair**

Company: **Style Ergonomics Australia Pty Ltd**

Load rating: For people up to **160 kg**

Multiple shift operation

Static load tested to 490 kg

The Australasian Furnishing Research and Development Institute (AFRDI) hereby certify the above specified product under the AFRDI Blue Tick Product Certification Program using certification criteria based on the following Standards and on additional requirements and variations as deemed appropriate by Furntech-AFRDI. For full test results and details of the specific components allowed on this chair, see Test Report 17283/1.

AFRDI 142 - Rated Loads For Office Swivel Chairs

AS/NZS 4438:1997 (R2016) Height Adjustable Swivel Chairs at Level 6 – Severe Commercial

The company, identified above, has agreed to maintain the compliance of the product represented on this certificate, and to submit to retesting and auditing as appropriate.

This certificate does not relate to the ignitability or durability of the chair's upholstery covering (e.g. fabric or leather). The chair's seat foam and back foam have been tested to the ignitability requirements of AS/NZS 4088.1 and found to be compliant.

This certification is valid for three years but may be suspended, revoked or renewed.



17283-5_240408_ct.doc

Australasian Furnishing Research & Development Institute Limited
 4th/44 009 579 908, trading as Furntech
 School Road (University Campus) Newnham Drive PO Box 2042 Launceston Tasmania 7250 Australia
 Tel (03) 6326 6155 Fax (03) 6326 3090
www.furntech.org.au Email: info@furntech.org.au



Standards, Testing and Product Certification for Commercial, Domestic and Nursery Furniture in Australia and New Zealand

INDOOR USE ONLY

X Do not use as a step ladder

INNER BACK LEVER

To adjust seat angle
(Forwards)

INNER RIGHT LEVER

To adjust seat height

RIGHT KNOB

To adjust weight tension

**720MM ALUMINIUM
5 STAR BASE WITH BRAKE CASTORS**

Use soft tyred castors for tiles
Use hard tyred castors for carpet

ADJUSTABLE HEADREST

ADJUSTABLE ARMS

LEFT KNOB

To adjust seat and
back angle

INNER LEFT LEVER

To adjust seat depth
(seat slider)

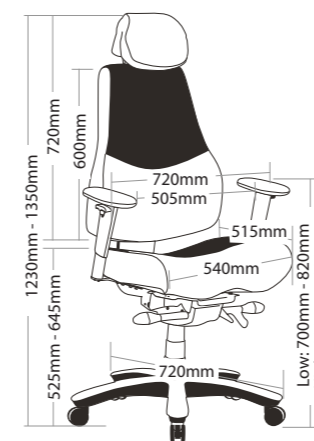

DUELER

*Please note that the Headrest should not be used to manoeuvre the chair.

CONTROL

MULTI SHIFT SEATING



FEATURES

Adjustable seat height || Adjustable seat and back angle || Forward seat tilt adjustment || Adjustable seat depth (seat slider)
 Adjustable weight tension || Adjustable lumbar support || Optional headrest || Adjustable arms || Moulded seat and back foam
 Saddle seat || Synchron mechanism with 3 locking positions || 720mm aluminium base || Brake castors
 AFRDI tested to level 6 || Multi shift use 200kg || Available in local fabrics || Suitable for indoor use only
 7 year warranty || Weight limit is 200kg



CONTROL-H



CONTROL-L



BACK VIEW



Approved by Furntech-AFRDI

*Check website www.furntech.org.au for current certification status

Certificate No.
17283/4

Nominal Expiry*
13 February 2027

RATED LOAD

Blue Tick
Product
Certification

Product name: **CONTROL**

Company: **Style Ergonomics Australia Pty Ltd**

Load rating: For people up to **160 kg**

Multiple shift operation

Static load tested to 490 kg

The Australasian Furnishing Research and Development Institute (AFRDI) hereby certify the above specified product under the AFRDI Blue Tick Product Certification Program using certification criteria based on the following Standards and on additional requirements and variations as deemed appropriate by Furntech-AFRDI. For full test results and details of the specific components allowed on this chair, see Test Reports 17283/1 and 17283/2.

AFRDI 142 - Rated Loads for Office Swivel Chairs

AS/NZS 4438:1997 (R2016) Height Adjustable Swivel Chairs at Level 6 – Severe Commercial

The company, identified above, has agreed to maintain the compliance of the product represented on this certificate, and to submit to retesting and auditing as appropriate.

This certificate does not relate to the ignitability or durability of the chair's upholstery covering (e.g. fabric or leather). The chair's seat foam and back foam have been tested to the ignitability requirements of AS/NZS 4088.1 and found to be compliant.

This certification is valid for three years but may be suspended, revoked or renewed.



17283-4_240408_ct.doc

Australasian Furnishing Research & Development Institute Limited

ABN 44 009 570 908, trading as Furntech

School Road (University Campus) Newnham Drive PO Box 2042 Launceston Tasmania 7250 Australia

Tel (03) 6326 6155 Fax (03) 6326 3090

www.furntech.org.au Email: info@furntech.org.au



Standards, Testing and Product Certification for Commercial, Domestic and Nursery Furniture in Australia and New Zealand

INDOOR USE ONLY

X Do not use as a step ladder

INNER BACK LEVER

To adjust seat angle
(Forwards)

INNER RIGHT LEVER

To adjust seat height

BACK KNOB

To adjust lumbar

RIGHT KNOB

To adjust weight tension

**720MM ALUMINIUM
5 STAR BASE WITH BRAKE CASTORS**

Use soft tyred castors for tiles
Use hard tyred castors for carpet

ADJUSTABLE ARMS

LEFT KNOB

To adjust seat and
back angle

INNER LEFT LEVER

To adjust seat depth
(seat slider)

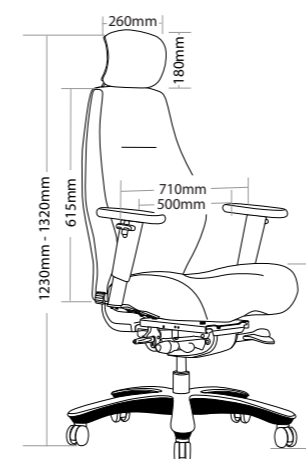

CONTROL-H

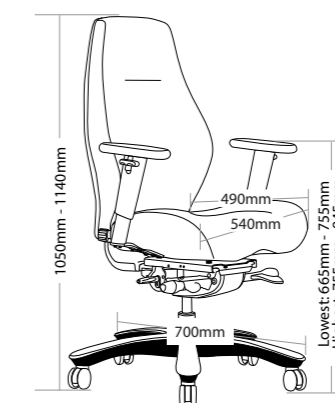

CONTROL-L

* Please note that the Headrest should not be used to manoeuvre the chair.

MAXI 4 ELGS

HOSPITALITY SEATING



FEATURES

Available with or without arms || Available in beam seating || Optional black or chrome finish
 Optional upholstered or mesh back || Plastic under pan || Plastic outer back (upholstered back only) || 4 legs frame
 Available in local fabrics || Back mesh available in Jazz mesh || Optional frame or base colour (please allow 5 more days)
 AFRDI approved to level 6 || Suitable for indoor use only || 5 year warranty || Weight limit is 120kg



M1



M1-B



M1-C



M1-BC



MM1



MM1-B



MM1-C



MM1-BC



Blue Tick Product Certification

Approved by Furntech-AFRDI

*Check website www.furntech.org.au for current certification status

Certificate No. **17308/1**
 Nominal Expiry*
28 February 2027

Product name: **Maxi 4 Leg Chair**
 Company: **Style Ergonomics Australia P/L**
 Product type: **Fixed height four leg chair**
 Seats: **1 person**
 Certified for: **General safety** ✓
Strength and durability ✓
Stability ✓
Upholstery foam/mesh ignitability ✓
 Test level: **6 – Heavy Commercial**

AFRDI Blue Tick certification criteria are based on **AS 4688 part 1:2018** and **AS/NZS 4688 parts 2, 3 and 4:2000 (R2016)** Fixed height chairs, but may include additional requirements and variations as deemed appropriate by Furntech-AFRDI.

Fabrics (or other upholstery foam coverings) have not been assessed as they are often specified by the customer. To comply with the care requirements of **AS 4688** fabrics must meet the care labelling requirements of **AS/NZS 1957**.

Testing and evaluation was conducted on the specified chairs, or selected samples from the range, such that in the opinion of Furntech-AFRDI all items (as tabulated below) should perform satisfactorily in relation to the certification criteria. Certification is limited to the features and options depicted and listed on this certificate.

The supplier having agreed to maintain the compliance of the product and to submit to retesting and auditing as appropriate, the Australasian Furnishing Research and Development Institute hereby certifies the product (as specified) under the AFRDI Blue Tick Product Certification Program.

This certification is valid for three years but may be suspended, revoked or renewed.

17308-1_240416_ct.docx

This certificate is not valid unless reproduced in full – Page 1 of 2



Standards, Testing and Product Certification for Commercial, Domestic and Nursery Furniture in Australia and New Zealand

Australasian Furnishing Research & Development Institute Limited
 44 499 576 068, trading as Furntech
 School Road (University Campus) Newnham Drive PO Box 2042 Launceston Tasmania 7250 Australia
 Tel (03) 6326 6155 Fax (03) 6326 3090
 www.furntech.org.au Email: info@furntech.org.au



Blue Tick Product Certification

Certified Features/Options
With and Without arms
Upholstered seat and back
Upholstered seat with mesh back
Non-stacking
Glides



17308-1_240416_ct.docx

This certificate is not valid unless reproduced in full – Page 2 of 2



Standards, Testing and Product Certification for Commercial, Domestic and Nursery Furniture in Australia and New Zealand

Australasian Furnishing Research & Development Institute Limited
 44 499 576 068, trading as Furntech
 School Road (University Campus) Newnham Drive PO Box 2042 Launceston Tasmania 7250 Australia
 Tel (03) 6326 6155 Fax (03) 6326 3090
 www.furntech.org.au Email: info@furntech.org.au

INDOOR USE ONLY

✗ Do not use as a step ladder



4 LEGS FRAME

Keep a permanent contact between base of chair and floor

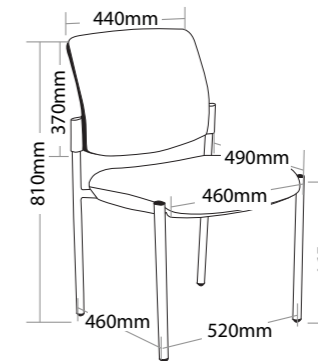

M1

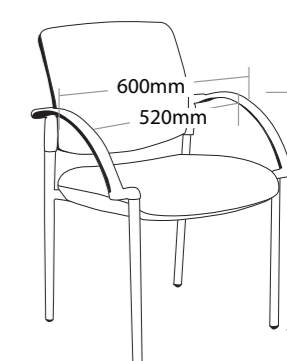

M1-B

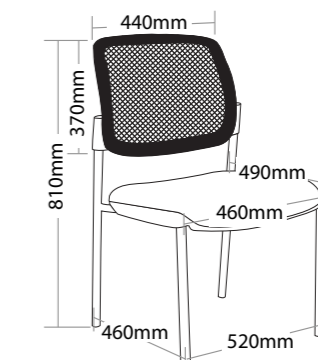

MM1

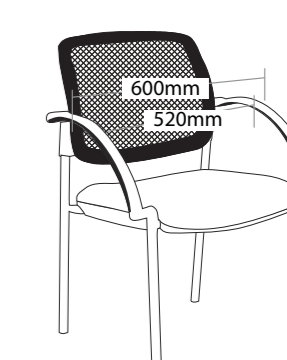

MM1-B

MAXI SLED

HOSPITALITY SEATING



FEATURES

Available with or without arms || Available in beam seating || Optional black or chrome finish || Optional upholstered or mesh back
 Stackable except with arms (Limit of 3) || Plastic under pan || Plastic outer back (upholstered back only) || Sled base frame
 Available in local fabrics || Back mesh available in Jazz mesh || Optional frame or base colour (please allow 5 more days)
 AFRDI approved to level 6 || Suitable for indoor use only || 5 year warranty || Weight limit is 120kg



M4

M4-A

M4-C

M4-AC



MM4

MM4-A

MM4-C

MM4-AC



Blue Tick Product Certification

Approved by Furntech-AFRDI

*Check website www.furntech.org.au for current certification status

Certificate No. **16983/1**

Nominal Expiry* **11 July 2026**

Product name: **Maxi Sled Base Chair**
 Company: **Style Ergonomics Australia P/L**
 Product type: **Fixed height sled base chair**
 Seats: **1 person**
 Certified for: **General safety** ✓
Strength and durability ✓
Stability ✓
Upholstery foam & mesh ignitability ✓
 Test level: **6 – Heavy Commercial**

AFRDI Blue Tick certification criteria are based on **AS 4688 part 1:2018** and **AS/NZS 4688 parts 2, 3 and 4:2000 (R2016)** Fixed height chairs, but may include additional requirements and variations as deemed appropriate by Furntech-AFRDI.

Fabrics (or other upholstery foam coverings) have not been assessed as they are often specified by the customer. To comply with the care requirements of **AS 4688** fabrics must meet the care labelling requirements of **AS/NZS 1957**.

Testing and evaluation was conducted on the specified chairs, or selected samples from the range, such that in the opinion of Furntech-AFRDI all items (as tabulated below) should perform satisfactorily in relation to the certification criteria. Certification is limited to the features and options depicted and listed on this certificate.

The supplier having agreed to maintain the compliance of the product and to submit to retesting and auditing as appropriate, the Australasian Furnishing Research and Development Institute hereby certifies the product (as specified) under the AFRDI Blue Tick Product Certification Program.

This certification is valid for three years but may be suspended, revoked or renewed.

16983-1_230719_ct.docx

This certificate is not valid unless reproduced in full – Page 1 of 2



Australasian Furnishing Research & Development Institute Limited
 School Road (University Campus) Newnham Drive PO Box 2042 Launceston Tasmania 7250 Australia
 Tel (03) 6326 6155 Fax (03) 6326 3090
 www.furntech.org.au Email: info@furntech.org.au

Standards, Testing and Product Certification for Commercial, Domestic and Nursery Furniture in Australia and New Zealand



Blue Tick Product Certification

Certified Features/Options
With and without arms
Upholstered seat and back or upholstered seat with mesh back
Stacking – without arms
Non-stacking – with arms
Glides



16983-1_230719_ct.docx

This certificate is not valid unless reproduced in full – Page 2 of 2



Australasian Furnishing Research & Development Institute Limited
 School Road (University Campus) Newnham Drive PO Box 2042 Launceston Tasmania 7250 Australia
 Tel (03) 6326 6155 Fax (03) 6326 3090
 www.furntech.org.au Email: info@furntech.org.au

Standards, Testing and Product Certification for Commercial, Domestic and Nursery Furniture in Australia and New Zealand

INDOOR USE ONLY

✗ Do not use as a step ladder

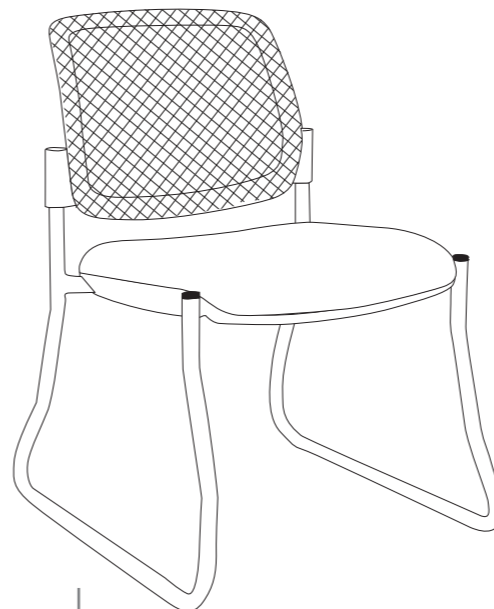

SLED BASE

Keep a permanent contact between base of chair and floor

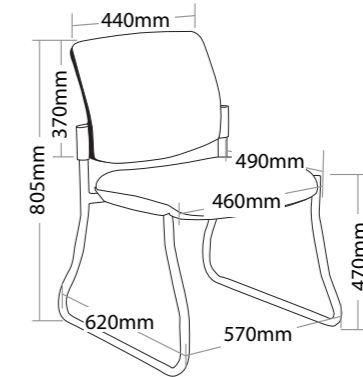

M4

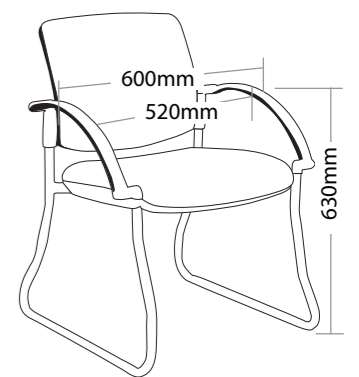

M4-A

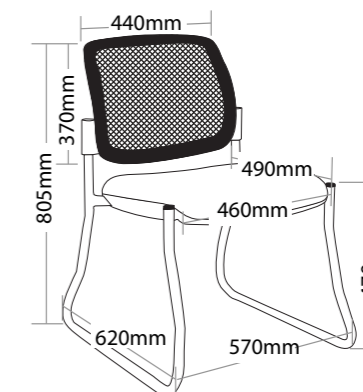

MM4

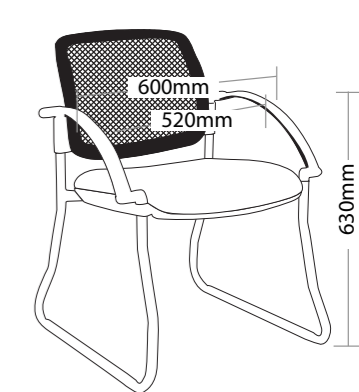

MM4-A

MOULDED FOAM

COMPONENTS



Approved by Furntech-AFRDI

*Check website www.furntech.org.au for current certification status

Certificate No.
18073/1
Nominal Expiry*
2 March 2027

Product name: **Style Moulded Seat Foam**

Company: **Style Ergonomics Australia Pty Ltd**

Blue Tick
Product
Certification

The Australasian Furnishing Research and Development Institute (AFRDI) hereby certify the above specified product under the AFRDI Blue Tick Product Certification Program using certification criteria based on the following Standards and on additional requirements and variations as deemed appropriate by Furntech-AFRDI.

AS/NZS 4088.1:1996 Specification for burning behaviour of upholstered furniture - Part 1 Upholstery materials for domestic furniture - Smouldering ignitability

AS 2282.3: 1999 - Method 3 Determination of apparent density of flexible cellular polyurethane

The company, identified above, has agreed to maintain the compliance of the product represented on this certificate, and to submit to retesting and auditing as appropriate,

Testing and evaluation was conducted such that, in the opinion of Furntech-AFRDI, the product designated on this certificate should perform satisfactorily in relation to the certification criteria.

The product is suitable for use in chairs certified to **AS/NZS 4438: 1997** - Height adjustable swivel chairs, and **AS/NZS 4688: 2000** - Fixed height chairs as either a seat or back foam up to and including level 6.

This certification is valid for three years but may be suspended, revoked or renewed.



18073-1_251023_ct.doc



Australasian Furnishing Research & Development Institute Limited
ABN 44 009 579 908, trading as Furntech
School Road (University Campus) Newnham Drive PO Box 2042 Launceston Tasmania 7250 Australia
Tel (03) 6326 6155 Fax (03) 6326 3090
www.furntech.org.au Email: info@furntech.org.au

Standards, Testing and Product Certification for Commercial, Domestic and Nursery Furniture in Australia and New Zealand



Approved by Furntech-AFRDI

*Check website www.furntech.org.au for current certification status

Certificate No.
18073/2
Nominal Expiry*
2 March 2027

Product name: **Style Moulded Back Foam**

Company: **Style Ergonomics Australia Pty Ltd**

Blue Tick
Product
Certification

The Australasian Furnishing Research and Development Institute (AFRDI) hereby certify the above specified product under the AFRDI Blue Tick Product Certification Program using certification criteria based on the following Standards and on additional requirements and variations as deemed appropriate by Furntech-AFRDI.

AS/NZS 4088.1:1996 Specification for burning behaviour of upholstered furniture - Part 1 Upholstery materials for domestic furniture - Smouldering ignitability

AS 2282.3: 1999 - Method 3 Determination of apparent density of flexible cellular polyurethane

The company, identified above, has agreed to maintain the compliance of the product represented on this certificate, and to submit to retesting and auditing as appropriate,

Testing and evaluation was conducted such that, in the opinion of Furntech-AFRDI, the product designated on this certificate should perform satisfactorily in relation to the certification criteria.

The product is suitable for use in chairs certified to **AS/NZS 4438: 1997** - Height adjustable swivel chairs, and **AS/NZS 4688: 2000** - Fixed height chairs as back foam only up to and including level 6.

This certification is valid for three years but may be suspended, revoked or renewed.



18073-2_251013_ct.doc



Australasian Furnishing Research & Development Institute Limited
ABN 44 009 579 908, trading as Furntech
School Road (University Campus) Newnham Drive PO Box 2042 Launceston Tasmania 7250 Australia
Tel (03) 6326 6155 Fax (03) 6326 3090
www.furntech.org.au Email: info@furntech.org.au

Standards, Testing and Product Certification for Commercial, Domestic and Nursery Furniture in Australia and New Zealand

MECHANISM

COMPONENTS



Approved by Furntech-AFRDI

*Check website www.furntech.org.au for current certification status

Certificate No.
18076/1
Nominal Expiry*
2 March 2027

Product name: **Style MECH24 & MECH 2A**

Company: **Style Ergonomics Australia Pty Ltd**

Blue Tick
Product
Certification

The Australasian Furnishing Research and Development Institute (AFRDI) hereby certify the above specified product under the AFRDI Blue Tick Product Certification Program using certification criteria based on **AFRDI Standard 109: Components for chairs - Part 5 - Office chair mechanisms** and on additional requirements and variations as deemed appropriate by Furntech-AFRDI.

The company, identified above, has agreed to maintain the compliance of the product represented on this certificate, and to submit to retesting and auditing as appropriate,

Testing and evaluation was conducted such that, in the opinion of Furntech-AFRDI, the product designated on this certificate, with the features listed below, should perform satisfactorily in relation to the certification criteria.

Tested samples of the products are maintained in the Furntech-AFRDI library for future comparison and audit.

Components that meet the requirements of this Standard are suitable, in terms of strength and durability, for use in chairs up to and including Test Level 6 of AS/NZS 4438:1997 - Height adjustable swivel chairs. Compliant components should not be assumed to be substitutable on assembled chairs without Furntech-AFRDI approval.

This certification is valid for three years but may be suspended, revoked or renewed.

Control Function	Implementation
Seat tilt adjustment	Continuous
Seat depth adjustment	Back tilt
Back height adjustment	Oval tube back upright
Controls	
Number	Two or three
Type	Simple lever
Handle	Paddle



18076-1_251028_ct.doc



Australasian Furnishing Research & Development Institute Limited
ABN 44 009 579 908, trading as Furntech
School Road (University Campus) Newnham Drive PO Box 2042 Launceston Tasmania 7250 Australia
Tel (03) 6326 6155 Fax (03) 6326 3090
www.furntech.org.au Email: info@furntech.org.au

Standards, Testing and Product Certification for Commercial, Domestic and Nursery Furniture in Australia and New Zealand



Approved by Furntech-AFRDI

*Check website www.furntech.org.au for current certification status

Certificate No.
18072/1
Nominal Expiry*
2 March 2027

Product name: **Style MECH26**

Company: **Style Ergonomics Australia Pty Ltd**

Blue Tick
Product
Certification

The Australasian Furnishing Research and Development Institute (AFRDI) hereby certify the above specified product under the AFRDI Blue Tick Product Certification Program using certification criteria based on **AFRDI Standard 109: Components for chairs - Part 5 - Office chair mechanisms** and on additional requirements and variations as deemed appropriate by Furntech-AFRDI.

The company, identified above, has agreed to maintain the compliance of the product represented on this certificate, and to submit to retesting and auditing as appropriate,

Testing and evaluation was conducted such that, in the opinion of Furntech-AFRDI, the product designated on this certificate, with the features listed below, should perform satisfactorily in relation to the certification criteria.

A tested sample of the product is maintained in the Furntech-AFRDI library for future comparison and audit.

Components that meet the requirements of this Standard are suitable, in terms of strength and durability, for use in chairs up to and including Test Level 6 of AS/NZS 4438:1997 - Height adjustable swivel chairs. Compliant components should not be assumed to be substitutable on assembled chairs without Furntech-AFRDI approval.

This certification is valid for three years but may be suspended, revoked or renewed.

Control Function	Implementation
Seat tilt adjustment	Continuous
Seat depth adjustment	Back tilt
Back height adjustment	Ratchet back upright
Controls	
Number	Three
Type	Simple lever
Handle	Paddle



18072-1_251028_ct.doc



Australasian Furnishing Research & Development Institute Limited
ABN 44 009 579 908, trading as Furntech
School Road (University Campus) Newnham Drive PO Box 2042 Launceston Tasmania 7250 Australia
Tel (03) 6326 6155 Fax (03) 6326 3090
www.furntech.org.au Email: info@furntech.org.au

Standards, Testing and Product Certification for Commercial, Domestic and Nursery Furniture in Australia and New Zealand

MECHANISM

COMPONENTS



Approved by Furntech-AFRDI

*Check website www.furntech.org.au for current certification status

Certificate No.
18065/1

Nominal Expiry*
2 March 2027

Product name: **Style MECH28**

Company: **Style Ergonomics Australia Pty Ltd**

Blue Tick
Product
Certification

The Australasian Furnishing Research and Development Institute (AFRDI) hereby certify the above specified product under the AFRDI Blue Tick Product Certification Program using certification criteria based on **AFRDI Standard 109: Components for chairs - Part 5 - Office chair mechanisms** and on additional requirements and variations as deemed appropriate by Furntech-AFRDI.

The company, identified above, has agreed to maintain the compliance of the product represented on this certificate, and to submit to retesting and auditing as appropriate,

Testing and evaluation was conducted such that, in the opinion of Furntech-AFRDI, the product designated on this certificate, with the features listed below, should perform satisfactorily in relation to the certification criteria.

A tested sample of the product is maintained in the Furntech-AFRDI library for future comparison and audit.

Components that meet the requirements of this Standard are suitable, in terms of strength and durability, for use in chairs up to and including Test Level 6 of AS/NZS 4438:1997 - Height adjustable swivel chairs. Compliant components should not be assumed to be substitutable on assembled chairs without Furntech-AFRDI approval.

This certification is valid for three years but may be suspended, revoked or renewed.

<u>Control Function</u>	<u>Implementation</u>
Seat tilt adjustment	Continuous
Seat depth adjustment	Back tilt
Back height adjustment	Ratchet back upright
<u>Controls</u>	
Number	Three
Type	Simple lever
Handle	Paddle



18065-1_251015_ct.doc



Australasian Furnishing Research & Development Institute Limited

ABN 44 009 579 908, trading as Furntech
School Road (University Campus) Newnham Drive PO Box 2042 Launceston Tasmania 7250 Australia
Tel (03) 6326 6155 Fax (03) 6326 3090
www.furntech.org.au Email: info@furntech.org.au

Standards, Testing and Product Certification for Commercial, Domestic and Nursery Furniture in Australia and New Zealand



Approved by Furntech-AFRDI

*Check website www.furntech.org.au for current certification status

Certificate No.
17662/1

Nominal Expiry*
25 November 2027

Product name: **MECH29**

Company: **Style Ergonomics Australia Pty Ltd**

Blue Tick
Product
Certification

The Australasian Furnishing Research and Development Institute (AFRDI) hereby certify the above specified product under the AFRDI Blue Tick Product Certification Program using certification criteria based on **AFRDI Standard 109: Components for chairs - Part 5 - Office chair mechanisms** and on additional requirements and variations as deemed appropriate by Furntech-AFRDI.

The company, identified above, has agreed to maintain the compliance of the product represented on this certificate, and to submit to retesting and auditing as appropriate,

Testing and evaluation was conducted such that, in the opinion of Furntech-AFRDI, the product designated on this certificate, with the features listed below, should perform satisfactorily in relation to the certification criteria. A tested sample of the product is maintained in the Furntech-AFRDI library for future comparison and audit.

Components that meet the requirements of this Standard are suitable, in terms of strength and durability, for use in chairs up to and including Test Level 6 of AS/NZS 4438: 1997 (R2016) - Height adjustable swivel chairs. Compliant components should not be assumed to be substitutable on assembled chairs without Furntech-AFRDI approval.

This certification is valid for three years but may be suspended, revoked or renewed.

<u>Control Function</u>	<u>Implementation</u>
Seat tilt adjustment	Continuous with tensioner
Seat depth adjustment	Back tilt and seat slider
Back height adjustment	Ratchet back upright
<u>Controls</u>	
Number	Four
Type	Simple lever
Handle	Paddle



17662-1_241014_ct



Australasian Furnishing Research & Development Institute Limited

ABN 44 009 579 908, trading as Furntech
School Road (University Campus) Newnham Drive PO Box 2042 Launceston Tasmania 7250 Australia
Tel (03) 6326 6155 Fax (03) 6326 3090
www.furntech.org.au Email: info@furntech.org.au

Standards, Testing and Product Certification for Commercial, Domestic and Nursery Furniture in Australia and New Zealand



Blue Tick
Product
Certification

Approved by Furntech-AFRDI

*Check website www.furntech.org.au for current certification status

Certificate No.
18075/1
Nominal Expiry*
2 March 2027

Product name: **Style CAST1 Black Castor**
with the following characteristics

- Free Wheeling
- Hard Tyre

Company: **Style Ergonomics Australia Pty Ltd**

The Australasian Furnishing Research and Development Institute (AFRDI) hereby certify the above specified products under the AFRDI Blue Tick Product Certification Program using certification criteria based on **AFRDI Standard 109: Components for chairs - Part 4 Chair Castor** and on additional requirements and variations as deemed appropriate by Furntech-AFRDI.

The company, identified above, has agreed to maintain the compliance of the products represented on this certificate, and to submit to retesting and auditing as appropriate,

Testing and evaluation was conducted such that, in the opinion of Furntech-AFRDI, the products designated on this certificate should perform satisfactorily in relation to the certification criteria.

The tested samples are maintained in the Furntech-AFRDI library for future comparison and audit.

Components that meet the requirements of this Standard are suitable, in terms of strength and durability, for use in chairs up to and including Test Level 6 of AS/NZS 4438:1997 - Height adjustable swivel chairs. Compliant components should not be assumed to be substitutable on assembled chairs without Furntech-AFRDI approval.

This certification is valid for three years but may be suspended, revoked or renewed.



18075-1_250926_ct.doc



Australasian Furnishing Research & Development Institute Limited
ABN 44 009 579 908, trading as Furntech
School Road (University Campus) Newnham Drive PO Box 2042 Launceston Tasmania 7250 Australia
Tel (03) 6326 6155 Fax (03) 6326 3090
www.furntech.org.au Email: info@furntech.org.au

Standards, Testing and Product Certification for Commercial, Domestic and Nursery Furniture in Australia and New Zealand



Blue Tick
Product
Certification

Approved by Furntech-AFRDI

*Check website www.furntech.org.au for current certification status

Certificate No.
18071/1
Nominal Expiry*
2 March 2027

Product name: **Style CAST11 Black Castor**
with the following characteristics

- Free Wheeling
- Hard Tyre

Company: **Style Ergonomics Australia Pty Ltd**

The Australasian Furnishing Research and Development Institute (AFRDI) hereby certify the above specified products under the AFRDI Blue Tick Product Certification Program using certification criteria based on **AFRDI Standard 109: Components for chairs - Part 4 Chair Castor** and on additional requirements and variations as deemed appropriate by Furntech-AFRDI.

The company, identified above, has agreed to maintain the compliance of the products represented on this certificate, and to submit to retesting and auditing as appropriate,

Testing and evaluation was conducted such that, in the opinion of Furntech-AFRDI, the products designated on this certificate should perform satisfactorily in relation to the certification criteria.

The tested samples are maintained in the Furntech-AFRDI library for future comparison and audit.

Components that meet the requirements of this Standard are suitable, in terms of strength and durability, for use in chairs up to and including Test Level 6 of AS/NZS 4438:1997 - Height adjustable swivel chairs. Compliant components should not be assumed to be substitutable on assembled chairs without Furntech-AFRDI approval.

This certification is valid for three years but may be suspended, revoked or renewed.



18071-1_250926_ct.doc



Australasian Furnishing Research & Development Institute Limited
ABN 44 009 579 908, trading as Furntech
School Road (University Campus) Newnham Drive PO Box 2042 Launceston Tasmania 7250 Australia
Tel (03) 6326 6155 Fax (03) 6326 3090
www.furntech.org.au Email: info@furntech.org.au

Standards, Testing and Product Certification for Commercial, Domestic and Nursery Furniture in Australia and New Zealand



Blue Tick
Product
Certification

Approved by Furntech-AFRDI

*Check website www.furntech.org.au for current certification status

Certificate No.
18074/1
Nominal Expiry*
2 March 2027

Product name: **Style CAST1-OFF/SF**
Style CAST11-OFF/SF
Black Brake Castor (Soft Floor)
with the following characteristics

- Friction Castor
- Hard Tyre

Company: **Style Ergonomics Australia Pty Ltd**

The Australasian Furnishing Research and Development Institute (AFRDI) hereby certify the above specified products under the AFRDI Blue Tick Product Certification Program using certification criteria based on **AFRDI Standard 109: Components for chairs - Part 4 Chair Castor** and on additional requirements and variations as deemed appropriate by Furntech-AFRDI.

The company, identified above, has agreed to maintain the compliance of the products represented on this certificate, and to submit to retesting and auditing as appropriate,

Testing and evaluation was conducted such that, in the opinion of Furntech-AFRDI, the products designated on this certificate should perform satisfactorily in relation to the certification criteria.

The tested samples are maintained in the Furntech-AFRDI library for future comparison and audit.

Components that meet the requirements of this Standard are suitable, in terms of strength and durability, for use in chairs up to and including Test Level 6 of AS/NZS 4438:1997 - Height adjustable swivel chairs. Compliant components should not be assumed to be substitutable on assembled chairs without Furntech-AFRDI approval.

This certification is valid for three years but may be suspended, revoked or renewed.



18074-1_251003_ct.doc



Australasian Furnishing Research & Development Institute Limited
ABN 44 009 579 908, trading as Furntech
School Road (University Campus) Newnham Drive PO Box 2042 Launceston Tasmania 7250 Australia
Tel (03) 6326 6155 Fax (03) 6326 3090
www.furntech.org.au Email: info@furntech.org.au

Standards, Testing and Product Certification for Commercial, Domestic and Nursery Furniture in Australia and New Zealand



Blue Tick
Product
Certification

Approved by Furntech-AFRDI

*Check website www.furntech.org.au for current certification status

Certificate No.
18074/2
Nominal Expiry*
2 March 2027

Product name: **Style CAST1-OFF/HF**
Style CAST11-OFF/HF
Black Brake Castor (Hard Floor)
with the following characteristics

- Friction Castor
- Soft Tyre

Company: **Style Ergonomics Australia Pty Ltd**

The Australasian Furnishing Research and Development Institute (AFRDI) hereby certify the above specified products under the AFRDI Blue Tick Product Certification Program using certification criteria based on **AFRDI Standard 109: Components for chairs - Part 4 Chair Castor** and on additional requirements and variations as deemed appropriate by Furntech-AFRDI.

The company, identified above, has agreed to maintain the compliance of the products represented on this certificate, and to submit to retesting and auditing as appropriate,

Testing and evaluation was conducted such that, in the opinion of Furntech-AFRDI, the products designated on this certificate should perform satisfactorily in relation to the certification criteria.

The tested samples are maintained in the Furntech-AFRDI library for future comparison and audit.

Components that meet the requirements of this Standard are suitable, in terms of strength and durability, for use in chairs up to and including Test Level 6 of AS/NZS 4438:1997 - Height adjustable swivel chairs. Compliant components should not be assumed to be substitutable on assembled chairs without Furntech-AFRDI approval.

This certification is valid for three years but may be suspended, revoked or renewed.



18074-2_251003_ct.doc



Australasian Furnishing Research & Development Institute Limited
ABN 44 009 579 908, trading as Furntech
School Road (University Campus) Newnham Drive PO Box 2042 Launceston Tasmania 7250 Australia
Tel (03) 6326 6155 Fax (03) 6326 3090
www.furntech.org.au Email: info@furntech.org.au

Standards, Testing and Product Certification for Commercial, Domestic and Nursery Furniture in Australia and New Zealand



Approved by Furntech-AFRDI

*Check website www.furntech.org.au for current certification status

Certificate No.
18063/1
Nominal Expiry*
2 March 2027

Product name: **Style BAS1-300 Black Base**

Company: **Style Ergonomics Australia Pty Ltd**

Blue Tick
Product
Certification

The Australasian Furnishing Research and Development Institute (AFRDI) hereby certify the above specified product under the AFRDI Blue Tick Product Certification Program using certification criteria based on **AFRDI Standard 109: Components for chairs - Part 3 Star bases - Five feet or more Strength durability and castor retention** and on additional requirements and variations as deemed appropriate by Furntech-AFRDI.

The company, identified above, has agreed to maintain the compliance of the product represented on this certificate, and to submit to retesting and auditing as appropriate,

Testing and evaluation was conducted such that, in the opinion of Furntech-AFRDI, the product designated on this certificate should perform satisfactorily in relation to the certification criteria.

A tested sample of the product is maintained in the Furntech-AFRDI library for future comparison and audit.

Components that meet the requirements of this Standard are suitable, in terms of strength and durability, for use in chairs up to and including Test Level 6 of AS/NZS 4438:1997 - Height adjustable swivel chairs. Compliant components should not be assumed to be substitutable on assembled chairs without Furntech-AFRDI approval.

This certification is valid for three years but may be suspended, revoked or renewed.



18063-1_250925_ct.doc



Australasian Furnishing Research & Development Institute Limited
ABN 44 009 579 908, trading as Furntech
School Road (University Campus) Newnham Drive PO Box 2042 Launceston Tasmania 7250 Australia
Tel (03) 6326 6155 Fax (03) 6326 3090
www.furntech.org.au Email: info@furntech.org.au

Standards, Testing and Product Certification for Commercial, Domestic and Nursery Furniture in Australia and New Zealand



Approved by Furntech-AFRDI

*Check website www.furntech.org.au for current certification status

Certificate No.
18063/2
Nominal Expiry*
2 March 2027

Product name: **Style BAS1-350 Black Base**

Company: **Style Ergonomics Australia Pty Ltd**

Blue Tick
Product
Certification

The Australasian Furnishing Research and Development Institute (AFRDI) hereby certify the above specified product under the AFRDI Blue Tick Product Certification Program using certification criteria based on **AFRDI Standard 109: Components for chairs - Part 3 Star bases - Five feet or more Strength durability and castor retention** and on additional requirements and variations as deemed appropriate by Furntech-AFRDI.

The company, identified above, has agreed to maintain the compliance of the product represented on this certificate, and to submit to retesting and auditing as appropriate,

Testing and evaluation was conducted such that, in the opinion of Furntech-AFRDI, the product designated on this certificate should perform satisfactorily in relation to the certification criteria.

A tested sample of the product is maintained in the Furntech-AFRDI library for future comparison and audit.

Components that meet the requirements of this Standard are suitable, in terms of strength and durability, for use in chairs up to and including Test Level 6 of AS/NZS 4438:1997 - Height adjustable swivel chairs. Compliant components should not be assumed to be substitutable on assembled chairs without Furntech-AFRDI approval.

This certification is valid for three years but may be suspended, revoked or renewed.



18063-2_250925_ct.doc



Australasian Furnishing Research & Development Institute Limited
ABN 44 009 579 908, trading as Furntech
School Road (University Campus) Newnham Drive PO Box 2042 Launceston Tasmania 7250 Australia
Tel (03) 6326 6155 Fax (03) 6326 3090
www.furntech.org.au Email: info@furntech.org.au

Standards, Testing and Product Certification for Commercial, Domestic and Nursery Furniture in Australia and New Zealand



Approved by Furntech-AFRDI

*Check website www.furntech.org.au for current certification status

Certificate No.
18067/1
Nominal Expiry*
2 March 2027

Product name: **Style BAS4 Chrome Base**

Company: **Style Ergonomics Australia Pty Ltd**

Blue Tick
Product
Certification

The Australasian Furnishing Research and Development Institute (AFRDI) hereby certify the above specified product under the AFRDI Blue Tick Product Certification Program using certification criteria based on **AFRDI Standard 109: Components for chairs - Part 3 Star bases - Five feet or more Strength durability and castor retention** and on additional requirements and variations as deemed appropriate by Furntech-AFRDI.

The company, identified above, has agreed to maintain the compliance of the product represented on this certificate, and to submit to retesting and auditing as appropriate,

Testing and evaluation was conducted such that, in the opinion of Furntech-AFRDI, the product designated on this certificate should perform satisfactorily in relation to the certification criteria.

A tested sample of the product is maintained in the Furntech-AFRDI library for future comparison and audit.

Components that meet the requirements of this Standard are suitable, in terms of strength and durability, for use in chairs up to and including Test Level 6 of AS/NZS 4438:1997 - Height adjustable swivel chairs. Compliant components should not be assumed to be substitutable on assembled chairs without Furntech-AFRDI approval.

This certification is valid for three years but may be suspended, revoked or renewed.



18067-1_250924_ct.doc



Australasian Furnishing Research & Development Institute Limited
ABN 44 009 579 908, trading as Furntech
School Road (University Campus) Newnham Drive PO Box 2042 Launceston Tasmania 7250 Australia
Tel (03) 6326 6155 Fax (03) 6326 3090
www.furntech.org.au Email: info@furntech.org.au

Standards, Testing and Product Certification for Commercial, Domestic and Nursery Furniture in Australia and New Zealand



Approved by Furntech-AFRDI

*Check website www.furntech.org.au for current certification status

Certificate No.
18070/1
Nominal Expiry*
2 March 2027

Product name: **Style BASE-8 Black Spider Base**

Company: **Style Ergonomics Australia Pty Ltd**

Blue Tick
Product
Certification

The Australasian Furnishing Research and Development Institute (AFRDI) hereby certify the above specified product under the AFRDI Blue Tick Product Certification Program using certification criteria based on **AFRDI Standard 109: Components for chairs - Part 3 Star bases - Five feet or more Strength durability and castor retention** and on additional requirements and variations as deemed appropriate by Furntech-AFRDI.

The company, identified above, has agreed to maintain the compliance of the product represented on this certificate, and to submit to retesting and auditing as appropriate,

Testing and evaluation was conducted such that, in the opinion of Furntech-AFRDI, the product designated on this certificate should perform satisfactorily in relation to the certification criteria.

A tested sample of the product is maintained in the Furntech-AFRDI library for future comparison and audit.

Components that meet the requirements of this Standard are suitable, in terms of strength and durability, for use in chairs up to and including Test Level 6 of AS/NZS 4438:1997 - Height adjustable swivel chairs. Compliant components should not be assumed to be substitutable on assembled chairs without Furntech-AFRDI approval.

This certification is valid for three years but may be suspended, revoked or renewed.



18070-1_250925_ct.doc



Australasian Furnishing Research & Development Institute Limited
ABN 44 009 579 908, trading as Furntech
School Road (University Campus) Newnham Drive PO Box 2042 Launceston Tasmania 7250 Australia
Tel (03) 6326 6155 Fax (03) 6326 3090
www.furntech.org.au Email: info@furntech.org.au

Standards, Testing and Product Certification for Commercial, Domestic and Nursery Furniture in Australia and New Zealand



Blue Tick
Product
Certification

Approved by Furntech-AFRDI

*Check website www.furntech.org.au for current certification status

Certificate No.
18066/1
Nominal Expiry*
2 March 2027

Product name: **Style CONBAS Chrome Spider Base**

Company: **Style Ergonomics Australia Pty Ltd**

The Australasian Furnishing Research and Development Institute (AFRDI) hereby certify the above specified product under the AFRDI Blue Tick Product Certification Program using certification criteria based on **AFRDI Standard 109: Components for chairs - Part 3 Star bases - Five feet or more Strength durability and castor retention** and on additional requirements and variations as deemed appropriate by Furntech-AFRDI.

The company, identified above, has agreed to maintain the compliance of the product represented on this certificate, and to submit to retesting and auditing as appropriate,

Testing and evaluation was conducted such that, in the opinion of Furntech-AFRDI, the product designated on this certificate should perform satisfactorily in relation to the certification criteria.

A tested sample of the product is maintained in the Furntech-AFRDI library for future comparison and audit.

Components that meet the requirements of this Standard are suitable, in terms of strength and durability, for use in chairs up to and including Test Level 6 of AS/NZS 4438:1997 - Height adjustable swivel chairs. Compliant components should not be substitutable on assembled chairs without Furntech-AFRDI approval.

This certification is valid for three years but may be suspended, revoked or renewed.



18066-1_250924_ct.doc

Australasian Furnishing Research & Development Institute Limited

ABN 44 009 579 908, trading as Furntech
School Road (University Campus) Newnham Drive PO Box 2042 Launceston Tasmania 7250 Australia
Tel (03) 6326 6155 Fax (03) 6326 3090
www.furntech.org.au Email: info@furntech.org.au

NSW BRANCH

A: 83-85 Percival Road, Smithfield 2164



VIC BRANCH

A: 21-23 Edison Rd, Dandenong South 3175



QLD BRANCH

A: 3 Aliciajay Circuit, Luscombe 4207



WA BRANCH

A: 22 Da Vinci Way, Forrestdale 6112

